

Converted on LSD Trip

Part 1

David Clarke

Published by

Bierton Particular Baptists

11 Hayling Close,

Fareham,

Hampshire,

PO14 3AE , UK.

16th January 2022

ISBN 978-1-4583-5288-0

E mail: Biertoncorrespondnet@gmail.com

Website: www.BiertonParticularBaptists.co.uk

Note From The Publisher

Publishers Preface

There are three separate accounts in the New Testament of a man who had been possessed with devils. He had been living among the tombs and the people had attempted to bind him with chains and fetters but he broke them so he would not be bound. People were afraid of him and avoided him. He had no house and wore no cloths and the devil drove him often into the wilderness.

And Jesus had just demonstrated his authority over the wind and the tempest to his disciples and now had commanded the unclean spirit to come out of the man and gave leave for the legion of devils to go into the swine and as a result the man was found at the feet of Jesus clothed in his right mind. The man wanted to be with Jesus and go with him, but Jesus said no but rather got to his own city and tell of all that the Lord had done for him. And straight way he went and published throughout the whole city of all that Jesus had done for him.

This book is a record of the personal testimony of the author in which he tells of what the Lord Jesus Christ has done for him it was first published on 11th February 2001 under the title, *Converted on LSD Trip*. It is not written to glorify his past life but written as a testimony to what the Lord has done for him, despite his past sinful and criminal life. In this he tells of his early life before his sudden conversion from crime to Christ, him learning the doctrines of the grace of God and him joining the Bierton Strict and Particular Baptists church, in 1976. He tells of his succession from the church over matters of conscience, in 1984. These matters are told in detail, in his book, 'The Bierton Crisis 1984'.

Even the apostle Paul told of his past life as a religious man in his own defense when persecuted by the Jews. He was a Hebrew of the Hebrews, circumcised the 8th day, Of the tribe of Benjamin, as toughting the Law blameless, not in a way of boasting but to show his past life, even though he was a religious man he considered it as worthless. He had been a Pharisee and from a religious zealous point of view persecuted the church even unto strange cities. He punished them oft in every synagogue, and compelled them to blasphemy, and being exceeding mad against them.

When the Apostle Paul was arrested by the lord on the Damascus Road he fell to the ground and Jesus instructed him that he was to make him a minister and a witness both of the things he had seen and those things He

would appear to him.

The author has written this book for this reason to inform the reader of all the that lord Jesus has done for him and to point out those important truths of the gospel of Christ.

This story was first publicised under the title, "Converted on LSD Trip", which was the front page headline of he Bucks Herald News Paper in Aylesbury Buckinghamshire on 11th February 1971. And now 30 years later written 11th February 2001. See page 15.

Please excuse the typo's, errors in grammar and spelling. I was virtually illiterate until the age of 21 after which I learned to read and educate myself.

Please take time to understand what I am trying to communicate as to get proof readers to work for love is very difficult.

I am sure the New Testament writers, some of which were unlearned men, had the same difficulties.

Contents

5

Publishers Preface	3
A Foreword by Malcolm Kirkham	8
B Foreword Dr Philip Fleming	9
C Foreword Gregg Haslam	10
D Foreword Samuel Ntoyimondo	10
E Fifty Years On; A Celebration	11
About The Author	13
1 Confession to 24 Crimes	15
(The court case)	15
What To Do With Stolen Goods After One Becomes A Christian	15
The Problem Was Solved By A Visit From The C.I.D.	16
Testimony of Barry Crown	17
Testimony of Cyril Bryan	18
Testimony of Mr E Connet	18
I Speak In Court	18
The Bucks Herald Weekly Paper	19
Seeking Truth	21
Voice Of Christ	21
Difficulty	21
I Tell My Story	22
2 My Early Life	23
3 Garston Infant School	30
German Teacher	31
David And The Hamster	31
Congregational Sunday School	32
Cecil The Sissy And Air Pistol	33
Wrexham Holiday	34
The Fair Ground, Stolen Bike	35
A Stolen Crystal Set	36
Stealing Radio Equipment	38
A Visit From The Police	38
4 Senior Secondary Schools	38
Michael and Boxing	38

6	My Visit to Soho	39
5	Our Move To Wilstone	40
	Keeping Myself Busy	41
	I Ride A 350 cc Triumph	42
	The Big Freeze 1962	44
	Short Stay Back To Watford	44
	My First Matchbox Radio	45
6	Aylesbury: Our New Home	45
	I Steel Push Bikes	47
7	I Meet Mrs Grace Knight	48
	My teenage years leaving School	48
	Conversation On The Intercom	49
	A Confident 15 year old	50
	A Holiday in Newquay	51
	The Headlands Hotel	51
8	Our Rock Group	52
	Steal An Amplifier Catholic Church	52
	The Fowler Mean our Rock Group	53
	A Secret	54
	Oxford Bags	58
	My First Girl Friend	59
	Carknapping (Steeling Cars)	60
	The Great Train Robbery	61
	The Kray Twins	62
	Kray's Imprisonment	63
	Mods Scooters, Bikes Bubble Car	63
	Pete Townsend Gives Us A lift	63
9	The Bubble Car	64
	Dr Clarke's Case	65
	Off To Margate	66
	Caught By The Police	67
	Bubble Car Blows Up	68
	I Get The Sack	68
	Plan A Break In	68
	The Break In	69
10	Canterbury Prison	70
	Canterbury Prison together	70

	7
Canterbury Prison in Kent	70
Hair Style Change	72
What Sentence Have You Got?	72
Wormwood Scrubs	73
Dover Borstal (The Citadel)	73
Borstal Boy	74
Electrical Installation Course	74
Paternity Suite	75
11 My Release From Borstal	75
Mods, Skinheads, Greasers at Yarmouth	77
Newquay Here We Come	78
The Beatles Magical Mystery Tour	79
Our Holiday A Place of the Sun	80
I Am A Waiter At The Gull Rock Hotel	80
We Return Home To Aylesbury	81
Our Trip To Shoreham	81
The History Of The Jews And 1967	81
Pat Jones And The Bully	82
12 Conversion from Crime to Christ	83
A Bad LSD Trip	83
Dave I Am With You	87
All I could Do Was Tell Them	87
Why Boast	88
13 What after Salvation	88
Evidence of the New Birth	88
What To Do With Stolen Goods	89
Seek To Tell Others	89
My own ignorance never read the Bible	90
Difference at College	90
I Tell Rupert	91
Turning From The world	91
Religious And None Religious Persons	91
Kept By The Power And Grace Of God	92

A Foreword by Malcolm Kirkham

I first met David Clarke around 1965 in Aylesbury, a town just north of London. David went to the local secondary modern Grange school and I went to the Grammar School. Our worlds collided though when through mutual acquaintance I found the R & B band he played for “Fowler Mean”. I joined as the singer. We became firm friends, the other band members were very straight and po faced but Dave and I connected I was aware of his older brother mike he was notorious in Aylesbury and no one messed with him. He was also an entrepreneur and extremely intelligent. On a different path Mike could have succeeded in any field.



Dave and I had many adventures during our times together. He was naturally inclined to steal however and his brazen nature astounded me. If he saw something he wanted he just took it. This is something he shared with his brother. Dave and I drifted apart when he was incarcerated along with his brother in one place and I in another for separate crimes. After 50 odd years we are in touch again. This book get details the life and times of a criminal, his redemption and his present day mission. It is also a snap shot of a period time and a place. End Of.

Malcolm Kirkham 06 May 2017

B Foreword Dr Philip Fleming

By Dr Philip Fleming MA. BA, Bch. FRCPsych. DPM



“Converted on LSD Trip”

This book, the personal testament of David Clarke, in an autobiographical style. It charts his life, which became one of criminality and drug taking though an experience in 1970 of finding God whilst under the influence of LSD. Cynics may say that this was just an effect of drugs, but it is clear that the experience changed his life. Later when in court facing charges he admitted to many other crimes and was fortunate in receiving three years conditional discharge and not a prison sentence.

Since then David has combined his work as a lecturer in electronics with his mission of spreading the word of God. This is a scrupulously honest book recording both the difficulties he has faced as well as the successes in his life since 1970. A continuing worry is the fate of his brother, currently serving a long prison sentence in a Philippine jail who himself has recently found God.

“This is an inspiring story of a life that has been turned from crime to a positive account and may be of help to others who find them selves directionless and involved in crime and drug misuse”.

Dr. Philip M. Fleming. MA. BA, Bch. FRCPsych. DPM.

Consultant Psychiatrist with special responsibility for drug and alcohol misuse.

C Foreword Gregg Haslam

Rev. Gregg Haslam Senior Minister Westminster Chapel, London



Gregg Haslam

“David Clarke tells the story of his troubled violent past and his extraordinary life, in such a way that it re-tells the story of Jesus’ love that’s available for us all. Christ has the power to renew and reclaim anyone’s wasted years, no matter we’ve done, or how deep our shame. He can re-launch our lives on a brand new future that we could never have planned for ourselves.”

Westminster Chapel



London SW1E 6BS

D Foreword Samuel Ntoyimondo

Chaplain HMPS Nottingham

“ This moving story demonstrates the goodness and mercy of God and it is a clear proof that no one is beyond God’s grace, mercy and love. Whatever wrongdoings we do, God continues to call us back to Him and if we accept, He fulfills His plan for us to give us hope for the future. “

E Fifty Years On; A Celebration



Fifty years ago David Clarke made a confession to the police of 24 crimes and appeared in Aylesbury Magistrate Court¹, on 9th February 1971.

In court Clarke related the reasons for his confession. In summing up and sentencing the Chairman of the magistrates said, “We have considered what we ought to do and have come to the conclusion that your evident desire to become a martyr is one thing we are not going to gratify”. He gave Clarke a conditional discharge for 3 years pointing out that the sincerity of your conversion could be shown by his behaviour during that period.

It was 30 years later, in September 1999, that David got news of his older brother Michael Clarke’s own conversion to Christianity. Michael had served 5 years, of a 16 year prison sentence², in the Philippines, that he decided to go on a mission of help to the Philippines³. This was to bring help and relief to his brother. This part of the story⁴ was reported as news by Portsmouth News. Their story was also reported in The Oldham Chronicle⁵, the town where the brothers were born.

David visited Michael in New Bilibid Prison, for the first time in 2001. This is the National and Maximum Security Prison. He visited Michael several times over the next four years and the brothers worked together within the prison with Religious Volunteers, and many prison inmates, seeking to help former criminals in their own rehabilitation.

The brothers vision was to equip former converted criminals to return to their own villages, towns or Cities and preach the gospel to their own friends and relatives.

The first inmate to be released with this commission was William O Poloc⁶ who was released, in August 2002, after serving 14 years for homicide. Several other prison inmates testified, in their own hand written accounts, their own stories of reformation, which David writes about in their book, Trojan Warriors, that contains 66 testimonies of converted criminals.

-
- 1 [Why he confessed to 24 crimes](#)
 - 2 [I Pray I might save my criminal brother](#)
 - 3 [Mission of Help 13th September 2001](#)
 - 4 [The News August 19th 2000](#)
 - 5 [Oldham Chronicle 11 January 2001](#)
 - 6 [Introducing William O. Poloc](#)

But Sadly Michael died⁷ of Tuberculosis in New Bilibid Prison before their vision of bringing help to many had been realized. Michael's story⁸ was reported in the Eastbound Herald, on 27th September, 2012,

Since August 2002, William Poloc⁹ has worked in Baguio City Jail and Benguet District Jails, working with inmates and former criminals, and founded several church groups, called Christ-Centered Churches and a Theological Institute.



God's work here in the Northern Philippines bloomed most especially here in the city of Baguio. The Baguio Christ-Centred Church is the mother church of all the Christ Centered Churches in the Philippines namely; The Pilot- Christ-Centred Church, The Kamog Christ-Centred Church, The Christ-Centered-Church Theological School(TULIP), The Christ-Centred Radio Ministry, The Christ-Centred Jail Ministries etc.). We'll,

we are truly blessed by these works He has entrusted to us. To God be the glory!

Website <http://www.bccc.com> (Facebook)

Email: williampolocr@yahoo.com

Christ-Centered Ministries Philippines

In celebration of this work David has republished and sent 12 theological books¹⁰ dedicated for the use of students, teachers and pastors and for Christs Centered Church groups. It is intended that these theological text books will be the basis of study for a theological degree, for qualifying students of Christ Centered Churches.

The publication date, of these books are by chance, 16th January 2020, which is virtually 50 years to the day of David's original conversion from Crime to Christ, which took place, on 16th January 1970. This Jubilee is the year of release , a practice of bringing release to those in captivity and, bondage and a release from old debts.

This mission of help was called Trojan Horse International.

David is now 71 years old and has been invited to visit and preach this year to the 10 affiliated churches, Baguio, but the Covet 19 lock down prevented it.

This new publication of *Converted On LSD Trip* tells the whole story

7 [Man dies in prison in the Philippines](#)

8 [Brother's Book looks at a former criminals life 27th September 2011](#)

9 [William Poloc's Testimony](#)

10 [A Body Of Doctrinal and Practical Divinity, Books I,II,III,IV,V,VI,VII](#)

About The Author

David Clarke, was born in Oldham Lancashire, in 1949.

During the 60's he and his older brother Michael began to enjoy lives of crime, promiscuity and infamy during their teenage years, whilst living in Aylesbury, Buckinghamshire, They lived with their parents and younger sister in Aylesbury and became criminals. They were both sent to prison in 1967 for malicious wounding and carrying a firearm without a license. David served his time in a young persons Borstal Training Institute at Dover, and Michael served his time in Maidstone Prison.

On leaving Dover Borstal in 1968, David was determined to have a good time living a life of crime, with no fear, or belief in God, respect for society, parents, or the wider family. He proceeded on a three-year career of undetected crime until he met a Christian woman who informed him that his life style was wrong.

It became David's opinion that Christianity was for people who could not enjoy life, or stand on their own two feet.

On the 16th of January 1970 David was arrested whilst he experienced a bad trip on LSD, but not by the Police. It was by Jesus Christ who spoke to him after he had cried out to God for help. Jesus said to David that the horrors that he had experienced was nothing compared to what hell was like.

David turned away that Friday night, from a sinful life of crime and immorality to follow Christ as best he could.

David began to read the bible immediately, and other Christian books, and attended a wide range of churches. He finally confessed to the police to 24 crimes that he had committed during his release from Borstal in 1968 and his conversion in January 1970.

David eventually joined the Berton Strict and Particular Baptist Church in 1974. And then trained as a Lecturer commencing teaching electronics at Luton College of Higher Education, and taught for 22 years in colleges of Higher and Further education, until 2001.

The Berton Church, which was founded in 1831, became a Gospel Standard listed cause in 1981, and in 1982 David was called by the Lord and sent by the church to preach the gospel where ever the Lord opened up the door for him to speak.

David then sought to reach his old friends from the past, and organized a preaching meeting at the Berton chapel in 1983, inviting all his old friends to come and hear of all what the Lord had done for him. Providentially that preaching meeting was televised on video and is available on YouTube under

the title:

[“David Preaching at Bierton Strict and Particular Baptist”, 5th June 1983”](#)
(Click to view).

David recalls that it became apparent after this meeting his real troubles began, and as a result he seceded from the Bierton Church in 1984. An account of this secession was written by David’s own hand entitled, “The Bierton Crisis”.

This story is a complete account of David’s early life, experience of conversion from crime to Christ and life in the Bierton Strict and Particular Baptist Church. He concludes that men may begin well in their faith towards God, trusting in the person and finished works of Jesus Christ alone for their salvation, but then **fall from grace falling** into the error of seeking to please God by works according to their own inventions or distortions of the Law of Moses. They fall into the trap of making themselves “**perfect in the flesh**” and then judge others who do not act like them.

The story continues to the time of Michael’s arrest in the Philippines, in 1995, and his 16-year prison sentence.

The story goes on through to Michael, David’s brother’s own conversion from crime to Christ, in New Bilibid Prison some 30 years after David own conversion to Christianity. This occurring after he was convinced that Jesus was the Christ, the son of the living God, through reading CS Lewis’s book, “Mere Christianity”. It tells of his baptism as a Christian in an old oil drum in that prison in September 2000.

This story demonstrates the manifold grace of God, in saving two brothers from a life of sin, crime and immorality, through the person of the Lord Jesus Christ.

This book is really David’s confession and testimony written for the **defence and confirmation of the gospel**. David also believes the things that have happened to him have fallen out rather unto the furtherance of the gospel. Phil 1. Verse and 7 and verse 12.

David’s solution to help and assist in the promotion of the gospel of the lord Jesus Christ is the creation of the Bierton Particular Baptist Open College (an Internet Cloud and also in the formation of Bierton Particular Baptist College in Pakistan. This is outlined in the last chapter of this book. Those wishing to be trained and educated In the doctrines of grace can enrol and obtain all the assistance they need.

1 Confession to 24 Crimes

(The court case)

It was real, absolutely real, but none of my friends really believed me. All I could do was tell them what had happened to me, and that was what I did. I told them all, the long, the short and the tall. As many of them as I could. They thought I had gone mad after taking LSD.

Jesus Christ had spoken to me and rescued me from a bad LSD trip on Friday evening, 16th January 1970. He had said that what I had been going through was nothing compared to what hell was like. I now knew the way and was determined to tell the others. I had become a Christian and no longer needed to live the life style that I had adopted, which had involved crime, drugs, promiscuity, flash cars and fame. I had been born again.

I was now responsible for sorting out all my stolen gear. What could be done with a builder's shed and stolen cars? I still had in my possession many stolen goods, which included the 48-foot by 24-Foot. Builder's shed, which we had stolen one night from a building site at Berkhamstead, and a lovely "G" reg. Mini, stolen from Hemel Hempstead, which was in the process of being "rung". Ringing meant replacing an old mini with legitimate registration documents and number plates with a new one. My new mini was being used to replace it. This was to be my new car. I also had a Morris Minor Traveller, which had been "rung" and was being used as a hire car. I had stolen garage equipment, which included an air compressor, electric welding equipment, spray guns and a trolley jack. I also had several pieces of electrical test equipment, which included oscilloscopes, AVO meters and Colour TV's. I had all the garage equipment I needed to repair and spray cars.

I had a lovely Citroen DS car in the builder's shed, which was being repaired. I obtained this car through swapping it for a colour TV set. The only problem was that I had stolen the TV set from an old people's home called Redfields, in Winslow, Buckinghamshire.

I also had two nice speedboat engines, getting ready for the summer of 1970. All in all I had had a real good time full of excitement and fun.

In fact I had been stopped in the midst of my career, which involved stealing all kinds of goods to have a good time. I had intended to have a caravan, a speedboat, water skis, aqualung diving gear, flash cars, motorbikes, clothes and so on, all through stealing. I was in fact stopped whilst in the midst of my career but not by the police. It was Jesus Christ who had called me by name and I followed him.

What To Do With Stolen Goods After One Becomes A Christian

I thank God he intervened again a year later and His hand was clearly seen

once more. I had no one else to help. As I write this I take encouragement in the faithfulness of God to me in never leaving me or forsaking me. I realize now I was kept through the power and grace of our Lord Jesus Christ to bare witness today, to many people of the goodness and mercy of God.

The Problem Was Solved By A Visit From The C.I.D.

I was sitting at the table in our kitchen at 37 Finmere Crescent one evening in late 1971, when a knock came on the door. I had two visitors, a detective constable Robson and a younger man. I was greeted quite politely but with sure and certain words “ You are charged with stealing a colour television set “ and “would you accompany us down to the police station to make a statement”.

I knew instantly what I must do and say. I saw the hand of God and believed this was all his doing but I did not know the outcome. Leaving the outcome to God I asked the two men to sit down in the kitchen and I admitted the charge. At this DC Robson seemed most relieved, for he said to me later, he had thought I would be very difficult and awkward and deny the charge.

I explained I would certainly come with them to the police station and make a statement but I wanted to speak to them about other things first. I said I had many crimes I wished to tell them about but wanted to tell them first of all why I was informing them.

I wanted it to be known that they would not have been able to find out about my crimes unless I confessed to them. I wanted to testify to the saving work of Jesus Christ that he had saved me from my former criminal way of life a year previously and that I did not wish to get off lightly with this confession but rather bear testimony for Christ. For in no way could my crimes be discovered unless I tell them and owned up to them. I had a lot of property, which could be returned.

I went with them to the police station and spent the rest of the evening making written statements giving details of my crimes. I was detained that evening in the police cells at Walton Street police station in Aylesbury, not that I was a stranger to prison cells. My shoelaces were removed but I was allowed my New Testament (Authorized Version, working man’s pocket addition).

I had to appear in Aylesbury Magistrates Court on the 9th February 1971 and answered two charges of burglary and one of theft. I also asked for 21 other crimes of theft to be taken into consideration, all of which had been committed since I left Borstal, between September 1967 and 16th January 1970. I had decided I did not need legal representation, as I would speak for my self.

With my past record of probation and Borstal training it was quite expected that I would be sent to prison. I was quite OK with this because I deserved it and I believed God was in this and had a definite purpose in this event. I prepared for this by setting my affairs in order at home and gave directions that my Mini Traveller, which I had rebuilt, was to be given to Barry Crown, if I got sent down. I believed that whatever happened to me the outcome was of God and there would be good reason for it. I thought I might be being sent to prison so as to preach the gospel to inmates. A friend of mine Mr Peter Murray was concerned about my court appearance and suggested I get some written testimonials from some of my Christian friends and he felt he ought to appear in person and speak on my behalf. The friends who wrote were Barry Crown, Cyril Bryan, Tom Thompson and Eric Connet. I am including these letters, which were sent to the court. These people all testify to the saving grace of God in changing my life. These are some of the written testimonies:

Testimony of Barry Crown

R.B Crown 45, Mitcham Walk, Aylesbury. Buckinghamshire

To the Clerk to the Magistrates

Dear Sir,

6th February 1971

I am a graduate of Salford University, and hold a B.Sc. in Civil Engineering. I am at present an employee of Aylesbury Borough Council, working under Mr. Hanney, the Borough Engineer and Surveyor. I have held this post since September 1970.

Shortly after taking up residence in Aylesbury I befriended Mr. David Clarke whom I met at the Full Gospel Church, Rick fords Hill. I found David to be a true and sincere Christian seeking to spread the Gospel of Jesus Christ and to give personal testimony of the salvation through Jesus Christ, which he himself had experienced.

David told me how he had been miraculously converted on January 16th 1970. And have the subsequent change in his whole manner and outlook to life. Before his conversion he confessed to a life of drugs and theft, but now he no longer had any desire or pleasure in such things, since Christ destroyed the power of such in his life.

For the six months I have known David I have been a witness to the truth of his testimony and I know him as a person who is a completely honest and trustworthy follower of the Christian faith.

Yours Sincerely,

R. B. Crown.

Testimony of Cyril Bryan

176 Cambridge Street Aylesbury

To the Clerk to the Magistrates

2/2/71

Dear Sir,

I am privileged to write a testimony to you concerning David Clarke, and I count it a privilege because it is to the glory of God.

I have known this young man through conversations and meeting with him, through the church I attend in Aylesbury. The Full Gospel Testimony Church at Rickfords Hill.

What I wish to bring to your notice is the wonderful change that has taken place in him as a result of him believing the gospel and receiving the Lord Jesus Christ as his personal saviour, according to the scriptural instruction and ordinances.

The change of character and speech is miraculous, as are all the works of God, and as a believer in the Lord Jesus Christ for 30 years; I know that David Clarke is a transformed person, by the grace of God. As are we all who know the reality of the new birth as taught by Johns Gospel.

You will know his past life, I testify to his new life in Christ Jesus. Yours Sincerely,

C Bryan.

Testimony of Mr E Connet

E.H. Connet

125 Park Street,

Aylesbury,

2nd February 1971

TO WHOM IT MAY CONCERN

This is to certify that I have known Mr. Clarke for a period of approximately 9 months since his conversion to Christianity. I am fully persuaded that he has turned his back on his past life and changed for the better.

He is now earnestly endeavouring to make amends for his past mistakes and even influence others to turn their lives over to God, as he has done.

My object in writing this testimonial is that it may help to throw some light on David's character from one who knows him as a Christian.

Yours Faithfully,

E Connet.

I Speak In Court

I appeared in court on the 9th February 1971, dressed in my dark blue (Mod) suit. I pleaded guilty and then a report from the police was read and I was given leave to speak for myself. I spoke extempore (without notes-

trusting in the Lord for all the help I needed) describing my pre-convention days up to my conversion. I also spoke about life since being a Christian explaining my difficulties with respect to the stolen goods that I had in my possession.

I was able to speak of what Jesus had done for me in a way that only God could have worked.

After this Peter Murray spoke on my behalf confirming my testimony.

This happened on Tuesday 9th February 1971, a date that proved significant to me 3 years later.

I was amazed, so were all my Christian friends. The magistrates thought I was trying to be a martyr. I do not know how or why. They obviously thought I should be sent to prison but part of my punishment would be I was not going to get what I wanted. God smiled. We smiled with him. It was good to be a child of God.

The Bucks Herald Weekly Paper

The whole court appearance was reported in the local newspapers and in the national Evening Standard

The news headlines of the Bucks Herald read, “ Why he confessed to 24 crimes” and “ Converted on LSD trip”. Whilst the Bucks Advertiser read “ Man speaks of horrors on LSD”.

The following are copies of those headlines all of which were fairly accurate.

FOR THE BEST IN USED CARS... Ford Main Dealer Aylesbury Motors

WHY HE CONFESSED TO 24 CRIMES

“CONVERTED TO LSD TRIP”

MICHAEL WEST, of

Card Park Road, Wendover, an insurance agent, has confessed to 24 crimes...

When asked why he confessed to 24 crimes and gave information leading to the recovery of £1,000 worth of stolen property...

Although he pleaded guilty to charges of stealing a 1960 colour television set from an old peoples home, a £200 spray gun and a hydraulic jack...

He asked for 21 other offences to be taken into consideration for his plea of guilty to stealing a builder's shop two cars, a bicycle, an electric air welder, two other television sets, two compressors and a road tractor.

IN THIS ISSUE

- Obituary page 2 Letters page 2 Entertainment page 4 Local Features page 6 Property page 6

HIDDEN - TREASURE

PLATINUM - GOLD - SILVER IS NOW AT ITS HIGHEST EVER... BE WISE - SELL NOW

LEGENT RESTAURANT... 11 GERRARD STREET, AYLESBURY

JOCK BEZANT... 11 GERRARD STREET, AYLESBURY

Phone BEZANT 2187-3... 11 GERRARD STREET, AYLESBURY

CRASH AT KIMBLE

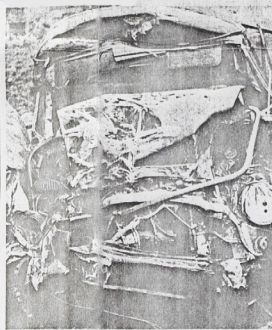

County rate jumps by 8.33 pence (1s. 8d. in the £)

THE RATE to be levied by Bucks County Council during the financial year starting in April is to rise to 55p each in the £.

The county finance committee agreed this figure at a meeting on Monday, and its recommendation will go before the full council for approval on February 25.

“Flimsy” assault case dismissed

A MAN SCARCELY NEAR a flimsier case than that, commenced by Mr. A. Widdowson, defending a man against charges at Aylesbury Magistrates' Court on Tuesday.

Hazell's redundancy talks

MR. TERRY HAZELL, aged 56, of 38, Chestnut Crescent, Princes Hill, Aylesbury, was taken to the Royal Bucks Hospital, Aylesbury, with severe multiple injuries after these two vehicles collided on the hill between the town and Little Kimble on Monday morning.

PROBLEMS AFTER THE POSTAL STRIKE ENDS

THE DELIVERY to central London districts has been held up for some time, but the difficulties are expected to be cleared up by the end of the week.

BROKE HER BACK IN FALL FROM TOILET WINDOW

AFTER TAKING A PACKET of paper handkerchiefs from Mr. H. Smith's shop at Aylesbury, a 40-year-old mother of two children fell from a toilet window, breaking her back. She was admitted to hospital the next morning and died there on Tuesday.

NARBETH'S SALE

DUE TO LATE DELIVERY OF SALE SHEETS WE ARE ABLE TO OFFER THE FOLLOWING AT REALLY OUTSTANDING PRICES

WHITECROSS WHITE COTTON SHEETS SEVEN YEAR GUARANTEE 70 x 100 normally 75/- 50/- FAIR 90 x 100 normally 85/- 60/- FAIR

Bucks Herald Script The Bucks Herald 11th February 1971.

David Clarke, who had a three-year career of undetected crime, experienced a "Christian conversion" whilst suffering from the effects of LSD, he told Aylesbury magistrates, on Tuesday. After wrestling with his conscience for the year, he confessed to 24 crimes, and gave information leading to the recovery of over £1000 worth of stolen property. In court he pleaded guilty to charges of stealing a £300 colour television set from an old peoples home, a £200 spray gun, and a hydraulic jack. He asked for 21 other charges to be taken into consideration, including stealing a

builders shed, two cars, and an electric arc welder, two other TV sets, two compressors, and a road trailer. Clarke (21) of Finmere Crescent said that his reputation in the town had been that of a man who was enjoying himself. "I used to sell drugs to young people, and indulge in permissive sex" he declared.

Seeking Truth

"Religion to me was rubbish, and for sissy people who could not stand on their own feet", he said. "Within my heart I was searching for truth, and a meaning to life". He had good prospects of getting on in life he went on but "was not satisfied with what I had, I was greedy, selfish and boastful." Clarke had been using pep pills, and marijuana since he was 16 he told the court, but it was after taking LSD that he experienced, what he described as, "a major thing in my life". He described the "torment" he suffered, as a result of taking the drug, and went on "I warn any young person who hears my testimony, "The effects of LSD are so bad, and I warn you to stay clear". While in this condition he said he, "Called on the name of Jesus" and his torment went from him.

Voice Of Christ

"Jesus Christ spoke to me as clearly as I speak here today saying, "David, I am with you".

Mr Murray, of Manor Crescent Wendover said he was habitually sceptical of sudden conversions, and preferred to put them to the test of time. The time, which had elapsed, since Clarke's profession of faith had convinced him that this young man would now be salt and light to society". "He is in truth, a new man, and had experienced what Christ called a second birth". Murray said Clarke now put himself out to be of assistance, read the bible intensely, always carried a New Testament, attended a wide circle of churches and would spend hours in discussion on spiritual things.

Difficulty

Clarke's difficulty during the months spent deciding how to make amends for his past had been the problem of accusing himself, without informing on others.

Passing sentence the chairman of the magistrates, Colonel I. Tetley, told Clarke, "You have pleaded guilty to three offenses and asked us to take into consideration 21 others, and except a record over a short period of time, which is quite the worst we have ever seen, we have considered what we ought to do and have come to the conclusion that your evident desire to become a martyr is one we are not going to gratify".

He gave Clarke a conditional discharge for three years pointing out that the sincerity of his conversion could be shown by his behaviour during that

The outcome of the court case was a complete surprise to us all, and we were overjoyed. A Christian friend, Mrs.. Chapski of Broughton Avenue Aylesbury, invited us all back to her home for coffee.

DC Robson informed me that they had discovered I was the person who had stolen the television from Mike West. An enemy of Mike West had tipped them off about the stolen Television. Mike West appeared in Court on the same day as myself and was fined £25. He nearly lost his job with the insurance company that he worked for. His encounter at court, to his embarrassment, also appeared on the front page of the newspaper alongside the article about my conversion.

After this I gave Mike West his Citroen car back that I had swapped for the colour TV. I had re sprayed it a bright Banana yellow, and replaced the engine. At lease he was able to sell it and get some money back. I now know, and take encouragement that God works well and sorts things out when we cannot do so.

As far as the other stolen goods were concerned the police managed to take away most of them but the firm who owned the builders shed sent a trailer. The ironic thing is that I could get no help to load the shed on the trailer. In the end Mrs.. Knight was the only one to help. This was very hard work but between us we managed to load it on the trailer late one night. To give you some idea of the value of the stolen items. The shed was said to be worth £400. The mini was brand new and worth £672. The price of a terraced house at that time was £2000.

I Tell My Story

I wish to tell my story starting when I was born (natural birth) and lead the reader until my conversion when the Lord Jesus spoke to me (second birth).

I then wish to speak about being a Christian and seeking to follow the Lord and meeting with the many and varied Christian groups and people. I wish to share with the reader how I learned the distinctive truths of the distinguishing doctrines of grace and sovereignty of God, which led me to joining the Berton Strict and Particular Baptist Church.

In this account I relate my call to preach and I list the many churches I share the gospel with until the very sad occasion of my secession from the Berton Church due to a departure for the truth. The church fell into the error of allowing general redemption being taught and a falling away into the error of the Law of Moses becoming their rule of life and conduct, rather than the Gospel. My secession being fully recorded on my publication, “**The Berton Crisis**”, which I now believe could serve as a real help to many churches as

in this account I name the many errors that I found to be prevalent, in those days amongst believers, and I point out the truth and scriptural view, which opposed those who held differing views.

It is my desire that this will serve to help and edify fellow Christians, and those seeking the truth as it is in Jesus Christ.

2 My Early Life

I was born on the 16th February 1949 at 9.50 AM, in Boundary Park General hospital, Oldham, Lancashire. My mother's name was Elsie Dyson Clarke who was married to my father Thomas George Clarke some time after the war. She informed me that this hospital was next to Oldham Athletic football ground.

We lived with my mother's father in his house at 26 Fleet Street, Clarksfield, Oldham. My granddad's name was Watts Ormrod and he was a retired craftsman and senior member of a Trades Union.

Boundary Park Hospital



This Is Where I Was Born

His hair was white, which I am told happened due to an accident at work when a large rivet was pushed through his hand. I had a brother, who was two and a half years older than me, Michael John (spelt Michael instead of Michael due to my mother's stubbornness when he was named at the registrar's office. The official informed her that the way she had spelt Michael was in fact wrong, and my mum reacted at being corrected and insisted it would be spelt just as she had written it.

The Clarke Family



Michael David Granddad Ormrod Dad Mum

My Parents



Thomas George Clarke Elsie Dyson Clarke

My mum and dad were both in the armed forces and were very proud to be British. Dad was in the Army and mum was in the Royal Air Force.

I was christened at Christ's Church, Glodwick and my Godfather was David Maltby of 382 Barton Road; Stratford and was a sides man at the Church on Barton Road. He gave me at that time a bible with a text of scripture written on the inside cover. Prov. 3. 6 "In all thy ways acknowledge him and he shall direct thy paths".

I have found a baptism certificate dated 3rd April 1949, where it states I became a member of Christ the child of God, and an inheritor of the "Kingdom of Heaven". This however is wrong, as I did not become a member of Christ until I was born again on The 16th January 1970, which I speak about later.

I remember attending the church and Sunday school at Christchurch,

which was just along the road from our house in Fleet Street. On one occasion I was so cosy, sitting on the pew, I fell asleep and woke up with a jolt wondering where I was, just as the vicar had finished his sermon. I had been lulled into sleep by the stimulating sermon. I haven't changed even to day. I must have been about 3 or 4 years old. It was my mother's idea to take my brother and I to Sunday school.

My Baptismal Certificate



David's Baptismal Certificate 3rd April 1949

St Barnabas School

At Sunday school I remember we painted pictures of houses and still remember wondering why did the teacher draw the house with the door in the middle of the building and windows either side of the door. This was because I knew we lived in a house in a terrace and our door was to one side, just like the other houses in the street. I had no spiritual impressions of the Lord Jesus Christ from these times.

Just across the street from our house there was a great Roman Catholic Church building, and living accommodation, surrounded by a high wall. It was built of red engineering bricks and several stories high with stained

glass windows along the long church building.

Barnabas Sunday School



St. Barnabas Sunday School Building

I remember looking up at the crooked lightening conductor and I still get the feeling of austerity and awkwardness when wondering what was behind that wall. It produced the same feeling in me when I had the story of Toby Twirl red to me. In that story he meets a giant who lived behind a great high walled castle. I was afraid to go near, or to even think of climbing the wall, or trespass in the grounds. I did not know it was a Roman Catholic Church building until about 25 years later when my mother informed me.

At that time I knew of no other religion than that of the Church of England, I assumed my mother was right in all such matters and so the Catholics were wrong.

I remember the street lamps because a man use to come around each night to light them as they were gas and he had a small ladder, which he carried with him, pointed at one end. He climbed the ladder and lit the lamps each night. I assume they were gas lamps.

Roman Catholic Building



The Roman Catholic Building

The Back Of Our House



Back Yard of 26 Fleet Street (Where I lived)

I remember my favourite sweets were what was called Kylie, it is called sherbet now. We could also buy a very small loaf of bread called a penny loaf.

At that time when I was about 4 years old I wanted to go to another Sunday school (I did not know at the time it was at a church building), which was at Lee's Road. My mother must have taken me there before. On this occasion it was Saturday morning and I did not believe there was no Sunday school that day. After being dressed I think my mother must have humoured me and did not take me seriously. I said I was going to Sunday school. I left home, I do not think my Mum realized and I walked at least two miles along

Balfor Street and along the busy Lee's Road and found the building, to my disappointment it was all locked up. On my return I wandered off and got lost and ended up asking for help from a Laundry Shop. They put me in the window as a lost boy and called the police. I was soon returned home. I think my Mum was horrified how far I had been.

Back Alley



Back Alley at 26 Fleet Street

I commenced my school days at "Clarks Field" Infants' School. My brother Michael John was already attending and was in the third year when I started.

Clark's Field Infants School



Clark's Field Infants School (David bottom right)

I remember my first day at school in the classroom with other children. The ceilings were high and there were things like sand pits and black board easels and old fashion classroom desks and tables.

The girl next door, Vivian Butler, began school with me and I can remember her crying for her Mum. I remember not feeling the need to cry and I tried to comfort her and assure her all would be well.

My Auntie Edith was very good to us boys and we would visit her every Saturday. She lived with my Granddad's sister. She was called Auntie Alice. Auntie Edith would take us out to a great park in Oldham and on the way home we would call in at the chip shop. In those days chips were real chips, cooked in real fat. One of our favourite meals she would cook was potato pie, with red cabbage. In the house there was a cellar, which I always liked to visit. I think at one time washing was done in the cellar.

At that time my brother was probably the only close friend I had, although we were not too close. He was just there. We use to go swimming on a Saturday morning to the "Waterhead Baths". This type of swimming baths was typical of the old-fashioned baths of the time. They were small, the water green, and walls tiled cream. At the side of the pool there were slipper baths where you could sit up to your chin in hot water and carbolic soap was supplied to wash with. It was very cosy. In fact the whole atmosphere was warm and cosy, not like the cold clinical swimming baths of modern times. Next-door was the washhouse where mum used to go at the same time to do washing.

One Saturday morning I nearly drowned and was saved by the attendant called Norman. I had tiptoed backwards and as the pool got slowly deeper and deeper I found I could not touch the bottom. It was through the providence of God that the attendant turned to see me reaching upwards out of the water. I couldn't speak. He dived in to rescued me and I can still feel the fear today of nearly drowning.

Across the road from the swimming baths was a slaughterhouse, next door to inhabited houses. We were very curious and would look through the slatted windows and see the men kill the pigs, sheep and cattle. This was awesome and ghoulish and a fearful thing, but we were very curious and wanted to see how the men slew the animals. There was blood, animal intestines, animal heads bones and blood. The smell was awful and not pleasant at all, and it seemed as though the pigs knew they were going to be slaughtered, and their end was come. I have wondered about my brother since then, as he was two and a half years older than me and how this may have affected him. Later on in life he demonstrated a callous way, which was characteristic of killing without mercy just like these slaughter men.

About this time I remember coming home from school and in the dusk of that day the house seemed unusually quiet. I noticed some blood on my brother's book and my mum told me there had been an accident. My brother had fallen down a basement stairway shaft at school and landed on his back. He was concussed and I remember then feeling how precious life was. My brother could have died through the fall. It was awesome. I still had no recollection of God during this time.

Oldham is a town in the north of England, not far from the city of Manchester, and during the 19th century was an industrial community famous for its cotton mills. In fact, my grandfather was a great supporter of the Trades Union.

As a child I remember the old mills, red brick built with huge chimneys towering high above the buildings. Also the water reservoirs, which we were always warned to stay away from. My mother had spoken about children being drowned in them and this was sufficient for me to obey her.

An Oldham Mill



Typical Old Mill Oldham

3 Garston Infant School

We moved from Oldham to Garston, Watford when I was 5 years old and my mum took me to my first day at school, which was at Garston Infant School. I was in the second year of the infants. My mum had arranged for me to walk home with a girl called Vivian who apparently lived in Coats Way where we lived. Not that I knew my address because I didn't. All I knew was we had move to a place called Garston, so I assumed we lived in Garston Road.

When it came to walking home I had to follow Vivian, but she took me by a way I had never been before. A completely different way, and across a

park to what was the other end of Coats Way. She left me there and I had no Idea where I was, as I did not recognize anywhere at all. Feeling uneasy about all this I realized I was lost. So I made my way back towards the school and began to ask people where Garston Road was. There was no such place but I insisted I lived in Garston Road. A man with a red Bedford dormobile offered to take me back to school to find out where I live so off we went. The schoolteacher said I lived in Coats Way where Vivian had took me but I said I didn't live there, as I could not recognize the place. The man took me back to Coats Way but I could not recognize where I lived. He drove from one end to the other. It was quite a long Way with a Council estate on one end and private houses at the other end. This was where I lived 149 Coats Way. I saw my Mum in the front garden - so I arrived home after being lost on my first day at school.

German Teacher

My classroom teacher was a German woman called Miss Kitchinger. She spoke with a German accent and I spoke with a broad Lancashire accent. We did not hit it off and I was hopeless at reading the flash cards. It seemed as though I was singled out and proved to be a dunce, as I could not really read. Being small I think I messed about to divert attention from my inability to do class work.

One day when I arrived at school I found a pair of pumps (they called them plimsolls now), which I later found out belonged to Vivian on my desk and I did not like them being there. Feeling rather indignant I place them in the dustbin. I think I might have asked the teacher, "please Miss, whose are these pumps?" But was ignored, as she did not understand me, so in the bin they went.

The next day Vivian's mother came to school wanting to find out where her plimsolls had gone. The caretaker said he had found them and placed them on my desk. When I was questioned I was in trouble and Miss Kitchinger said my mum would have to buy a new pair as I had thrown them away. I felt this unfair and felt really picked on. I know my mum came to the school and had an argument about the pumps and the fact that a German teacher was trying to teach English. This was only few years after the war with Germany had ended.

David And The Hamster

At that time my mum had to work late and it was arranged for me to wait in the classroom after school until my mum came to pick me up. This was shortly after the event with the plimsolls. The class had a pet hamster and this little creature got all the attention from every one. I was the one that got no attention but rather got into trouble. One evening whilst I was waiting in

the classroom for my mum to collect me, the teacher left the classroom for a short while.

I went towards the hamster cage and thought to my self why do you get all the attention. I know what I am going to do with you. I took the hamster out to the cage and closed the door. I looked at the hamster in the in the eyes and went over to Vivian's desk and put it inside, shutting the lid quickly thinking that will pay her back for getting me in trouble over her plimsolls. I sat back in my chair before the teacher returned and went home with my mum as though nothing had happened.

The next day I went into class as quiet as I could and keeping out of the way. I waited patiently for the eruptions. Then suddenly, Oh Miss, screamed Vivian, the hamster is in my desk. It had weeded and messed everywhere through out the night. Every one gathered around the desk to see at the same time. I felt very guilty. One boy tried to suggest the hamster had escaped and climbed up the table leg and got through the whole drilled for the spilled ink to drain. A good idea I thought so keep thinking that thought. Then some one asked how did it get out of the cage as the door was closed. I was feeling very, very guilty now and wondered if Miss Kitchinger was thinking had I done the deed the night before. I kept quiet and to this day they do not know how that hamster got there. During this time my brother was attending the Lea Farm Junior School, the school I was to attend the next year or so.

Congregational Sunday School

My mum use to take me to Sunday school from time to time and I didn't mind going. One day (about 1958) on the way home from normal school I would walk past the Congregational church building, rather a modern building, and the vicar lived in a Gypsy stile caravan in the church grounds.

Garston Congregational Church Building



Congregational Church Building

The church building was always left open and we often went in the church building on the way home. I saw, on one occasion, some boys took the money out of the collection box, which too was left unlocked. I could not understand this. Why were things left unlocked for boys to steal from. One day after school I met the vicar when I was looking around the church building and I asked him why is the building left open and why is the collection box not locked. His reply puzzled me. He said the church should be always open for people because God was like that if people felt they need to steal the collection then they must need it badly. He did not feel the box should be locked. I was puzzled and said but why? The vicar was sure it was the right thing to do. That stayed with me to this day and people get angry some times with me for not locking up my house.

At this same church I can remember the Easter services. I had no idea what the gospel was nor did I understand the Easter story.

I remember sitting in the pew during the Easter service listening to how they crucified Jesus wondering why Jesus did not come down from the cross. I felt he could have done so and confounded all them Pharisees, but why didn't he do so. I knew the story about his death and resurrection but did not know what it all meant. I never did find out until 14 years later when I was 21 years old when I learned to read the bible for my self. It was then I learned that Jesus had to die to take away my sins. That he died in my place to set me free from sin, self and death.

It was about this time (1959) that my mum encouraged me to play the piano. My mum's favourite artist was Perry Como and "Side Saddle" was a piece of mum's favourite music, which I learned to play. I had music lesson with a Miss Mary Lee, a music teacher in Garston and eventually I graduated with a merit Grade 1 (Primary) RSA in Pianoforte. This was July 1960.

The sort of music, which was popular in those days, was. "Yellow Polka Dot Bikini, My Old Man's a dustman, by Lonnie Donnigan, Living Doll by Cliff Richards. Also the Hula-Hoop was a craze at that time.

Cecil The Sissy And Air Pistol

Living not too far away from us in Coates Way, was a boy who my brother nicknamed Cecil, as this sounded like a suitable name for a sissy. He was a cripple in the sense that his feet were curved inwards and he walked awkwardly. He must have been about 10 years old. My brother poked fun at him and I too soon followed suit. We would sing about him a song called Cecil, Cecil a Cecil feet. He would try and avoid us.

One day Cecil came on his bike down to the woods that we called the dell. We were playing up the trees and had made a catapult out off one of the great branches of the trees. One person would sit in the branch and two

or three other kids would pull on the rope till the branch was fully bent. The rope would be released and the person would be catapulted up in the air. They would have to hold on tightly other wise they would end up in the trees.

On this day my brother had it in for Cecil. We took his bike and put it into the catapult making sure it was catapulted up into the trees. We thought this was great fun but Cecil did not.

His mother came to our house and complained to my mum about our bullying Cecil but my mum seemed to have no mercy. She said Cecil had got to learn to look after himself and he was a sissy. I felt mum was wrong as I knew how bad we were and my mum seemed to have no mercy. I felt bad however.

Shortly after this incident my brother encouraged me to take our newly acquired air pistol to school, and Cecil was the one who my brother bullied and threaten to shoot in the playground. On reflection my brother seemed to have no mercy at all. My brother must have been in the final year and I in the first year of Lea Farm Junior School.

David at Lea Farm Junior School



David At Lea Farm Junior School

It wasn't long however before my air pistol was found and confiscated. After assembly one of the boys had taken it out of my desk and was running around the classroom with it when the teacher walked in. I was in trouble again with the Headmaster and this would have been another time I got the cane for bringing a dangerous weapon to school.

Wrexham Holiday

Michael and I must have been about 7 and 10 years old and Mum and dad had renovated an old Ford convertible car whose number plate was BBU.

Mum had bought the car whilst we were living in Oldham and dad was

working in Watford. Dad had moved to Watford to get a job, and was living with his mum (our grandma at Ash Tree Road Garston, Watford). Mum and dad were able to buy a house at 149 Coats Way Garston and it was mum who decided to buy the car to get Michael and I down from Oldham to Watford.

It was this car that I often fell out of when the breaks were hit. It caused me to move forward and push open the door lock and the door opened the opposite way round. I would end up on the road outside the car. Dad eventually was able to put a safety chain on the handle to stop this happening.

Dad had rebuilt the engine and painted it black and green, Mum made a new convertible top using her sewing skills. It was a bit like Noddy's car it was really good.

In this car we went to Brixton for a holiday and it was there mum and dad bought Michael and I a fishing rod each. I had a wooden cane one and he had a metal rod. I remember I was always jealous of what he had as I always thought his things were better than mine.

Keen to try the rods out near the sea harbour Michael rushed to the waterside just around the corner and soon came back crying. He said a man had taken his rod and thrown it into the sea. Dad rushed around but no one could be seen. We looked for the man on his bike but no one was to be seen. It is only now that I look back that I believe Michael had quickly put the rod together pretended to fish by casting an imaginary line and the rod top had gone straight into the sea. He probably felt he would have been told off by our dad and be in trouble. So he invented a story about a man on a bike.

When I look back it is incidences like this that I learned about the way Michael thought and worked and in later life it made one wonders at the tales he told.

The Fair Ground, Stolen Bike

Every year the fair would come to Garston and I really looked forward to ride the dodgem cars. All the kids would go to the fair and spend lots of time watching. I can remember two brothers who worked on the fair and these were like heroes, and we would wonder who was the strongest and speculate which one could lift a dodgem car above his head. We would also listen to the latest pop music, which played through large loudspeakers. This was before any one had personal radios or cassette players. There was no Top of the Pops on TV. So the fair was the place to hear pop music.

I was probably about 11 or 12 years old, and this year I remember stealing £3 from my mum's purse. I felt very guilty and bad at the time and I still feel the shame as I write about it now, but this was spent on the fair. I am thankful for the truth that the blood of Jesus cleanses us from all sin. This became my only way of me dealing with my sin when I became a Christian

36
and still is.

My brother at that time had a paper round and use to get up early each morning and so he began to earn his own money. I remember him obtaining all sorts of new things like writing cases, pens, pencils, ink cartridges, etc. all the little things one would like but could not afford. I soon realized that my brother was not buying them but stealing them from the shop where he worked.

On the odd occasion I would go and help him deliver the papers. I enjoyed this as it took me to places I had never been before.

On one occasion we had to deliver papers to a hospital or residential home, and around the back of the building we could see the kitchens and we helped our selves to the cakes, which had been freshly cooked. I learn from my brother how easy it was to get things I wanted.

I always looked up to my brother and often envied the things he did and had. I remember him going to Switzerland, with the school and him coming home with all kinds of goods. Like a walking stick, flick knives, and badges etc. Flick knives were illegal and to have a flick knife was a good thing.

My brother soon got in to bows and arrows, and air rifles and pistols swords and sheath knives, which seemed good to me. In fact we use to hide all these weapons under the floorboards in our shed, which was at the bottom of our garden.

At this time I remember my mum and dad buying me a new bike. It was a red Californian, with curved crossbars etc. I thought it was great and was ever so pleased with it. One day the bike went missing, and I knew some one had taken it, so I was very upset.

When I went out looking for it I noticed up the road an accident had taken place, as there were cars stopped and people milling around. To my horror I saw my nice new bike crumpled and just lying at the side of the road. The boy who had taken it had been knocked off the bike and was lying in the road awaiting an ambulance and every one was trying to take care of him.

I thought to my self never mind about him, as he had stolen my bike, but look at my new bike, all bent. I was very upset. No one however took any notice of me, neither were they concerned about my bike being damaged. The boy's name was Michael Abbes and we had been friends until recently and I seem to remember that he had broken his legs in the accident.

A Stolen Crystal Set

My interest in radio, which we now call electronics, started the day I heard a crystal set operate. I must have been 10 or 11 years old.

My mum and dad belonged to the Camping Club of Great Britain and

every weekend we would go camping to Chertsey, where we had a tent pitched.

One weekend my brother stole a crystal set from a camper's tent. It consisted of a small tuning capacitor in a blue plastic case and a crystal diode, together with a set of headphones. I was amazed as it worked and became interested in radio from that day forward.

Camping at Chertsey



Dad at Chertsey Camp-site Dad By Our Canoe

I sent away for a set of parts to build a two transistor reflex receiver, and put the thing together as best I could. I wired the circuit as I thought the diagram showed, and crushed it all together to fit inside its plastic case. It didn't work and I was most disappointed. I didn't realize that all the wires were shorted together when I crushed it into the plastic case. Another friend of mine's dad helped me out. He was a radio technician in the Royal Air force and he rebuilt the receiver and showed me how to wire circuits up. From that time I began to learn about how things worked and taught my self-many things with the help of others.

Another friend of mine had a dad who had a radio workshop and I was very envious of all the equipment that he had in his garage. I remember the boy being confident enough to take apart out of an old radio for me, without any sense of fear. I was quite impressed. I taught my self quite a lot and began to learn about transistors.

One day on the way home from school we climbed over the fence of someone's back garden and discovered a shed full of radio parts, and equipment. There were valves, tuning condensers, transformers etc., we took what we wanted and thought no more of it.

This hobby was to last me a long time and helped me to get a job in radio and television servicing and to Technical College at a later date. During this time I had no sense or knowledge of God and I had stopped going to Sunday school.

Stealing Radio Equipment

One day on the way home from school we climbed over the fence of someone's back garden and discovered a shed full of radio parts, and equipment. There were valves, tuning condensers, transformers etc., We took what we wanted and thought no more of it.

This hobby was to last me a long time and helped me to get a job in Radio and Television Servicing and to Technical College at a later date. During this time I had no sense or knowledge of God and I had stopped going to Sunday school.

A Visit From The Police

About this time I manage to break into a work man's hut which was at the gravel pit situated on not to far from our home. Me along with other kid would play there during the evening and climb on top of the work man's working shed. There were also two large tanks of hot water and we would after dangle our feet in the water and wash our selves after getting dirty. On this occasion we managed to break in the shed and I managed to steal a wireless receiver. It was a valve receiver in a wooden box. I took it to pieces and saved the chassis and had it in my bedroom at Coats Way. Some how the police were tipped off and they came and searched our house for the stolen goods. I was thankful I had got rid of the wooden cabinet as they found no evidence of the break in.

4 Senior Secondary Schools

My first senior school was in Garston, as I had failed the 11 plus. It was at this school I first heard a boy play a tune called , "Apache" by the Shadows, on an acoustic guitar and I was very impressed. Michael had already started at this school and did well at cricket, boxing and basketball. I was not good at any of these things but rather was interested in my radio hobby.

Michael and Boxing

I soon learned the my brother had a reputation at school as a boxer and I recall attending the school competition for sports and Michael won the boxing at that event. He would have been in the fourth year and about to leave school. On that occasion my uncle John and Dad were there and Uncle John after Michael's win went and congratulated the looser, in order to keep him encouraged. Parents were like that in those days.

Michael at Butlin's



Michael In The Horizontal Striped Jumper
The Senior Clarke Brothers



Uncle John and my Dad Tom Clarke

My Visit to Soho

It was towards the end of my first year, at Francis Coombe Secondary modern school, that I ventured out to London on the train, with a friend of mine, Paul Dorrington. This was to visit the second hand electrical shops, to buy radio parts. I loved visiting Tottenham Court Road for this purpose and it was on one of these visits that we stumbled across Soho and noticed the strip clubs.

These aroused our curiosity. Paul and I plucked up courage and paid to go in and sit at a table. We could see a nude lady sitting on a chair and were given a sketchpad and pencil and encouraged to draw her picture. I felt I was growing up. Afterwards we paid one or two more visits and became wiser.

When we moved to Wilstone, a village near Tring in Hertfordshire, my

radio and television hobby helped me pass the time and kept me out of too much trouble.

5 Our Move To Wilstone

In 1961 we finally moved to Wilstone a village near Tring and Michael and I went to Tring Secondary modern school called Mortimer Hill. I can remember my brother wearing winkle picker shoes and some of the girls from the next village couldn't help but say oh look at those shoes. They were just different and I suppose they felt threatened.

Michael at Tring School



Michael With His Friend Notice the Winkle Picker Shoes

It was during this time that I taught myself more about Radio and amplifiers.

I became absorbed in this hobby. I met a man in the village called Cluck Turney, who was the man to know about televisions and radios and he gave me a lot of help. He taught me about valve amplifiers and allowed me to build a power amplifier, from all the spare parts that he had. It was a push pull amplifier using two PX4 valves and a triode driver. I had to rewind the driver and output transformers in order to get it working. I learned a lot from Cluck Turney.

Amplifier Construction



Amplifier Using PX4 Valves

On one occasion I was able to connect a microphone up to my amplifier and I directed the speaker out of my bedroom window and spoke to people out side our shop. On this occasion I saw a woman in her rear garden called Ethel. I called out with the amplifier as loud as possible saying Ethel, Ethel I am watching you. I heard many years later that she thought it sounded a bit like God speaking from the sky.

Keeping Myself Busy

To occupy myself I made things of interest. I made a kart with a large wind sale.



My Land Yacht

A pair of stilts and all the kids in the village wanted a pair. On one occasion I made an electric shock machine from an ignition coil a battery and a mechanical vibrating mechanism used in an electric bell. I tested it out on the kids in the village by getting them to hold hands, in a circle and one kid at each end of the circle held the electrode.

When I switched the machine on they all got a sharp electric shock. It

42
was a success.

Keeping Busy



Electric Shock Machine

I later had a visit from the local policeman as I had stolen a 12-bore shotgun from an old barn and brought it home. When I showed it to my next-door neighbour he recognised the gun and realised who it belonged too and so he informed the local policeman to get it returned to its owner.

Stolen Shot Gun



Stolen Shot Gun From the Farm

Whilst at Tring School a friend of mine Duncan Miller found a baby fox cub in a wood, and I wanted to keep it so I took it home. Unfortunately my Grandma, who had come to stay, freaked out when she saw it as she was frightened and to my dismay my brother killed it and to this day I felt he was callous.

I Ride A 350 cc Triumph

My brother mixed with all the lads who had bad reputations and no

one would dare up set them and he was in the final year at Tring Secondary Modern school. He was friends with all the lads who were in trouble.

One friend was Bod Shearer, who lived on a farm in Tring and I recall Michael having an old 350 cc, Triumph motor bike, with girder front forks. I took courage and rode this bike in the field and was quite pleased with myself for having the courage to ride such a big bike. I had, until that time, only ridden a moped.

The Motorbike



Michael's 350 CC Triumph Motor bike

It was during this time at Wilstone my brother got sent to his first spell in Detention Centre. He had made a knuckle-duster at school, in the metal work classes, and tried it out by hitting some boy in the village. What happened was some lads had found our moped in the field and had a go at riding it without our permission. Not that they would know whom to ask, but my brother felt he would sort them out for riding it. I think it was an excuse to use the knuckle-duster he had made.

When the police were called in he made out the knuckle duster was made as a part for the moped and my mum was certain this was true and she defended my brother to the hilt. I knew it wasn't true and my brother did a spell in Detention Centre for 3 months, for grievous bodily harm. I did not go along with my brother's violence and could not understand it. His reputation spread and at school the teachers began to identify me with my brother and I think they began to be wary of me too.

My brother mixed with all the lads who had bad reputations and no one would dare up set them.

Village life proved too much for my mum and she became depressed, due to the way things were, and the trouble Michael had gotten into so it was decided to sell up and move to a new house in Aylesbury.

The Moped



Our Moped in Wilstone Field

The Big Freeze 1962

Once we had sold the village shop mum and I moved to Oldham whilst Michael and my dad moved into lodgings in Aston Clinton. This was while the house they had bought off plan was being built. Mum and I moved to live with my aunt Edith at 26 Fleet Street, in the town where I was born and had to go to school. This was Clark's Field Senior School and I became a bit of a celebrity simply because I was from "London". This status increased when I told the "lads" about my trips to Soho. It was here that I first heard of the Beatles as they were playing in Oldham at that time. The song I remember that was popular, "Love me do", by the Beatles, which came out in October 1962.

During my time in Oldham we were there for about three months, I built a balsa wood, controlled line, aeroplane, a radio transmitter for a remote control aircraft and learned to ice skate. We had a very cold winter, the coldest on record and the snow fell and the streets froze over. My mum bought me a pair of second hand ice skates and I learned to skate on the frozen streets in Oldham.

Short Stay Back To Watford

After staying for while in Oldham we moved back to Watford and lived with my Dad's mum. On this occasion I had to go back to Francis Coombe Secondary School and I renewed acquaintances with my former friends. It was during this time I made my own transistor radio set. This was before printed circuit boards were available. It was a two transistor reflex receiver and I was very proud of it, as it was the size of a matchbox. I also missed riding the moped and so I got up very early one morning and walked into Watford where I knew a motorbike was parked and stole it. I drove several

miles to a secret place and parked it up and went home. I later used it for joy riding with my friends. I walked miles that morning and my mum never knew about it.

Michael also would visit us at Watford and see his old friends who played in a pop group and on one occasion he gave me a pair of bell-bottom trousers and a shirt, with a long pointed collar. Michael and his friend wanted to take me to the dance that was held at Leavesdon, on a Friday or Saturday night. I really enjoyed myself there and wanted to go again. I met some of my friends from school there and one boy noticed my clothes and said that I was a Mod.

Unfortunately for me after this I began to get bullied at school by a group of boys who were what you might call "Jack the Lads". I learned afterward the reason and it was to do with Michael. One of the boys was from Australia and was the ringleader of this gang and he had a girl friend at the school called Pat Petty. She was every boy's dream of a girl. Well Michael had met her at the Leavesdon dance and chatted her up. This Australian boy was jealous and as soon as they realised that I was Michael's brother they had it in for me.

My First Matchbox Radio

It was during this time (13 years) I obtained a circuit diagram for a Two transistor Reflex Receiver and with the components.

My Two Transistor Wireless Receiver

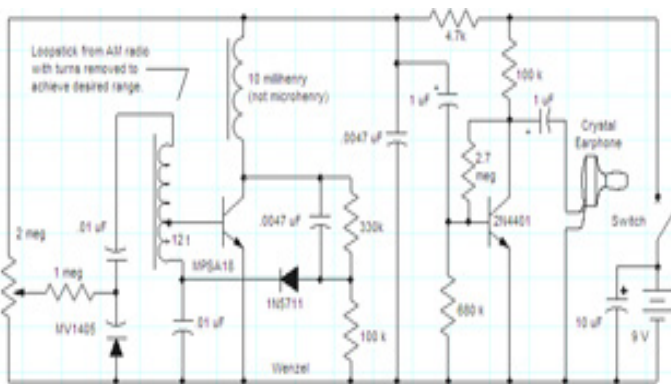

Here Is The Circuit Diagram

I obtained from Tottenham Court Road, London, I built this on a small paxolin board. This was before printed circuit boards were readily available. I was very pleased with this as it had good sensitivity and selectivity and was about the size of a matchbox.

6 Aylesbury: Our New Home

Our new house was situated on the Bedgrove Estate, in Aylesbury and was ready for us to move in April of 1963. However before we left Wilstone I

had enjoyed riding a moped in an old orchard, in the village. It belonged to a friend of Michael and I was allowed to ride this moped. It was a 50 cc NSU Quickly and was kept in his orchard.

Once we had moved into our new house in Aylesbury I was able to return to Wilstone and take the engine from the moped frame and put the engine in a home made go kart. I made this go- kart from builder's wood that I took from the building site. I use the moped engine, a set of wheels from a child's three wheeler tricycle, and various parts from a cement mixer. I then began to ride this machine around the new roads on the housing estate. However I was eventually stopped by the local police and warned that it was illegal to ride this Go Kart on the roads and soon after that the local newspaper came and gave me a write up in the Bucks Herald.

David's Do It Your Self-kart



David's Do It Your Self Kart 1963

An Aylesbury boy was able to return to school after the Easter holidays and proudly tell his friends, " I've made a Go Cart in the holidays." He is 14 years old,

On Sunday of last week a friend gave David (pictured above) and old moped. As he was unable to ride it he as he is too young he dismantled it. He

then made a Kart frame from some pieces of wood, four old wheels and a set of handlebars and the moped engine.

My NSU Quickly Moped



My Moped

Within three days it was in working condition and David estimates it will do 20 miles and hour.

Incidentally David, who has lived in the town for only a month has very little real interest in engines. His main hobby is in radio construction work and one of his proudest possessions is a transistor radio, which he built that is slightly larger than a matchbox.

I Steel Push Bikes

It was during this space of time, before starting my new school; I met another lad called Ian Motrem. We encouraged each other to steel push bikes. In fact the first day that I went to school I stole a bike to come home from school.

I eventually got a Francis Barnet 150 CC motorbike, which my brother had stolen from Aylesbury College, with some other lads. I kept this in a field on the Bedgrove Estate near our home. It was great fun to have a motorbike and I would ride across the fields to school and return home during my lunch hour. However one day some one stole my motorbike and Ian Motrem informed me that he thought he knew the person that had taken it. I went to this person's house early one morning, during my paper round, and found a motorbike in his garage. This wasn't my bike but I took it anyway. This ended up in me being charge with garage breaking and being put on probation for two years.

Stolen Francis Barnett 150 CC Motor Bike



My Francis Barnett Motor Bike

7 I Meet Mrs Grace Knight

My teenage years leaving School

My first recollection of any religious person having any effect on my life was when I was about to leave school, at the age of 15 years old.

My mother had spoken to a Mr K H Knight who was the proprietor of Central Bucks T.V. and had arranged for me to have a part time job working after school and on a Saturday. This was until I left school and took up full time work as an apprentice to Mr Knight.

I am told years later that my letter of job application was so badly written and the spelling so awful it was laughable. However I was taken on despite my inability to write, spell or use correct grammar, or read properly. This was during my last year at school.

I first met Mrs. Grace Knight, one Saturday morning, whilst working for her husband Ken. She was in hot pursuit of her husband and shouting at him for doing some thing she disapproved of.

I was in the workshop, with Norman Garret the other apprentice, and I thought- wow what an awful dragon of a woman and pitied Mr Knight from that moment on.

Through Mr Knight (Ken) I was introduced to the Radio and Television servicing trade and often went with him into customer's houses to repair TV's and install television aerials.

I spent many hours with Ken going to peoples homes and soon learned that he was not faithful to his wife. Not that it bothered me, as I knew what Grace was like from our first meeting. The idea of sexual promiscuity was

very attractive to me. When we went out enjoying our selves Mrs. Knight would be left at home or in the workshop minding their two children Allison and Mark. They also had a big dog called Rufus.

By this time I had left school and was interested in our band, as we wanted to make music. Ian Myers was the bass guitarist and he built his own guitar amplifier from a circuit design and published in Practical Wireless. He built the amplifier I helped him with the speaker cabinet and it was used in all our future gigs.

I soon began to realize the things I enjoyed were not the things Mrs. Knight approved of, or found interesting. I thought she was a right “kill joy” and was boring. She was a Christian what ever that meant and I soon realize her values were not the same as mine. What I considered good and enjoyable she would call it sin and sinful. She would also complain to her husband that I was always with him and he gave her no time. It seemed she was often driven to despair by him never being in on time and being very unreliable. He would often leave her for hours whilst we were at work out on jobs.

Conversation On The Intercom

On one occasion Norman Garret’s mum complained to Mrs. Knight the Norman her son, was not getting the training he needed because Ken was always taking me out with him. I heard this conversation over the shops intercom. Mrs. Knight said yes I was a nuisance and she did not like me one bit and it was not good that I should be out with her husband all the time. Upon hearing this I felt angry and went down the stairs to where they were and confronted them both saying that I had heard what they had said about me. They were embarrassed and I am sure this did not help our relationship. I really thought Mrs. Knight was an ogre.

I began to attend Luton College of Technology, to learn about Radio and Television Servicing, and travelled by bus, one day a week, from Aylesbury to Luton; it was about an hour’s and a half’s run. I think it must have been due to Mrs. Knight and her religion that I began to notice the texts of scripture put up out side churches as I past by on the bus, they were called “Way side pulpits”. I began to memorize the verses such as:

“ Righteousness exalteth a nation but sin is a reproach to any people”

And also another:

“ Jesus said if you find life difficult learn of me and the burden I shall give you will not be too difficult to carry”.

At that time I had no idea of the meaning of these texts of scripture but found it amusing to quote them to Mrs. Knight at any in appropriate moment thinking it would embarrass her.

On one occasion I remember being dressed in an old blanket made

into an undercoat from my brothers Mod anorak. I was standing on the corner of the street near to the workshop one Saturday morning with Mr and Mrs. Knight. I quoted at the top of my voice these two scriptures in order to embarrass Mrs. Knight. I am not sure how they felt about it but little did I know that one day I would learn the truth of these texts and become a preacher of the Gospel myself.

Mrs. Grace Knight became a great help to me and lived until 2001. Here is a link to a video of her funeral.

(Click to view)

[Obituary Grace Maude Knight](#)

A Confident 15 year old

I enjoyed working for Mr Knight because he seemed to appreciate my help and abilities and would trust me to drive the van at 15 years old. On one occasion he was short of a driver and had to deliver a television. So he dressed me up in a sheepskin coat and gave me dark glasses to wear with instructions to deliver a TV to a house in Quarendon. I was very pleased to do this even more when it turned out that I was delivering the TV set to one of my school friends called Gillespie.

On another occasion I was given the job of replacing a complete I.F. Board on a new Ferguson 850 T.V. receiver in a customers home. A qualified engineer in a workshop setting normally would have done this but this unconventional approach was normal to me. Mr Knight had complete confidence in me at the age of 15 years old. I am sure the customer was not at all happy at this 15 year old repairing their lovely brand new Television receiver.

During this time I was still making music in the group and when I was 16 Mr Knight's business failed and went into liquidation so I found myself another job. I got an apprenticeship with Sale and Mellor at Radio a TV shop in Aylesbury. I worked there until I got in trouble with the police when I was sacked at the age of 17 years.

Stolen BSA Bantem



BSA Bantam 125 CC Motor Bike

It was shortly after this time that I got into trouble with the police for breaking into a garage and stealing a motorbike. I had a Francis Barnett 150 CC, which had been stolen from the field where I kept it and a friend of mine told me that it was in this garage, along the Tring Road. At first I was just interested in getting my bike back but when I opened the garage door I was disappointed not to find it - just a 125 BSA Bantam.

I thought well its better than nothing so I decided to take it any way and wheeled it out of the garage and back to our field, to use it later. The police later caught me and for this first crime I was charged with garage breaking and put on probation for two years.

A Holiday in Newquay

At this time Mum and Dad took me and my sister Margaret , who was about 3 years old, to Newquay for a holiday. I didn't know what kind of place it was but when we got there it was great. The sand the sea and the surfing and views were a treat to see. It was here that I conducted my first blag (a scheme or scam) as I wanted to explore the Headland Hotel, which was an impressive hotel.

The Headlands Hotel

Anyway on this occasion I took Margaret by the hand and we walked down the drive right into the hotel. As we approached a steward of some kind came up to me and asked if he could help. I confidentially replied no thank we are staying here. He stood upright, in embarrassment and said, oh yes I remember the little girl. So we blagged it and I wondered around the hotel with my 3 year old sister, admiring the hotel.

The Hotel Where The Witches Was Filmed



The Headlands Hotel Newquay

My brother and I were to returned to Newquay for a holiday in 1967 just before we were both sent to prison.

8 Our Rock Group

It was after this that decided I wanted to play the electric guitar and I remember a lad called Alan Lawrence, from Tring Secondary Modern School, having an electric guitar and bringing it to school. He plugged it into the schools record player and it sounded great. I wanted to learn to play like him. The first guitar I owned was an electric Hofner Futurama Two and a friend called Steve showed me how to play Twist and Shout and it was this that got me really interested to play properly.

Steal An Amplifier Catholic Church

I put together my own guitar amplifier using the P.A. amplifier that I had stolen from the Catholic Church on the North Orbital Road in Watford. It didn't bother me even when my conscience spoke to me about it being wrong to steal as I believed the Catholics were wrong anyway according to my mum.

My First Guitar Stolen Amplifier



Liner Concord 30 Amplifier

Top View using EL34 Output valves in push pull

Underneath the Chassis



Hand Wired Main Chassis

(I had inherited a prejudice against the Catholic Church, from my mum, and so when I took the amplifier I ignored my conscience by saying to myself they were wrong any way).

I then began to get more interested in making music and during my last year at school we formed a band and we played at the end of term school dance. Our Gym teacher, Mr Pottinger, organized this event.

The Fowler Mean our Rock Group

Ian Myers was the base guitarist and later Robby Woods became our lead guitarist. On that occasion though, at the school do, Willie Barrett was lead guitarist. He was the only one of us to make musical fame. He became

known as Wild Willy Barrett and played music with John Otway.

Wild Willy Barrett



Wild Willy Barrett

A Secret

Willy Barrett's dad was a brilliant man, a musician and a craftsman, he made an excellent bass guitar for either Willy or his friend. He wanted an amplifier for Willie's electric guitar and the bass player friend said he had a 30 Watt Linear Concord amplifier for sale, for a small amount of money and I jumped in quickly before they made their mind up and bought it from this man. This is the one in my picture.

How ever I then agreed to sell my 15 Watt linear Concord amplifier that I had stolen from the Catholic Church, in North Watford to his dad for a little bit less money and they bought it of me. I was very pleased but felt a bit guilty because they got a rough deal and really they should have had the 30 Watt amplifier which was much better than mine. Little did they know I had stolen the amplifier.



Wild Willy Barrett and John Otway

My Vox A.C. 30 Amplifier



My Vox AC 30 (Cost Second hand £60)

I had a new amplifier that was a Vox AC 3.0. and replaced the amplifier that I had stolen from the Catholic Church. One of our regular spots, on a Saturday night, was Courts Dance School, just off Kingsbury Square. Here is our music play set:

[The Fowler Mean \(Play Set\) Click to view and listen](#)

After leaving school we reformed the group and began to play music at various dance halls and I named the group “The Fowler Mean”.

We often played at Courts School of dancing in George Street in Aylesbury and other venues in Aylesbury. In Tring and the Bulls Head and the Anthony Hall in Aston Clinton. One of the other bands we played with was The Must Be Blue with the organist Pat Archer.

We would play all cover music by groups such as, The Rolling Stones, The Who, The Small Faces, The Kinks, Otis Reading and John Lee Hooker. We played, “My Generation”, but I knew it was not quite right and I never did find out how to play the right cords to this day. The opening chords we played were four down strokes on G followed by four downward strokes on F but that is not right. I always thought if ever I met Pete I would ask him to show me how to play those opening chords. I really enjoyed playing with the band but was eventually sacked and it was then that Malcolm Kirkham and I began to knock around with each other.

The Fowler Mean



Dave Clarke (left) with Robby Woods (top) Ian Myers

Our Favorite Band The Who

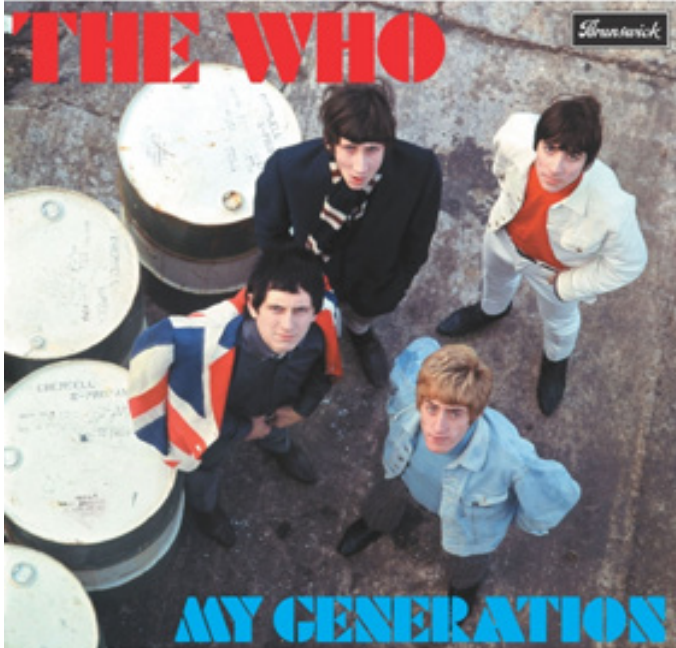

John Entwistle, Pete Townsend, Keith Moon, Roger Daultary
My favourite band was The Who. This group introduced something to

music that was new. It was volume. My Generation was the real hit that made the Who. I can remember hearing them, at the Grosvenor Dance Hall, in Aylesbury. Pete Townsend was the lead guitar, John Entwistle on bass, Keith Moon on drums and Roger Daltary lead singer. There was not a band to touch them they were brilliant. We saw them on a number of occasions including places like Borehamwood and the Bedford Corn Exchange.

I remember their amplifier line up (being interest in amplifiers) Pet Townsend had:

Pete Townshend Amplifier line Up



Two A.C. 100 Amplifiers in Parallel

John Entwistle Amplifier line up



4 X A.C. 60 watt Vox Bass

Amplifiers and their PA system was Vox columns and Shure microphones. The volume added another dimension to the experience. I call it Rock

and Real Music, It added depth to the sound and none of us had experienced anything like it before

These were all classic Who numbers and none forgettable pieces of music Malcolm Kirkham use to be one of our singers which made 5 in the band and we use to go out together on our scooters. I had inherited my brother's Lambretta TV 175 CC and Malcolm had a 150 CC new Lambretta and we began to mix with the Mods in Aylesbury and district.

He had been sacked from the group because he messed about. Malcolm would always arrive late and never be in time to set up the equipment. He was always combing his hair or having to press his trousers, and he general fooled around. He was nicknames Cocoa the clown.

After mixing with the other lads in Aylesbury I soon found out my brother was well known and when it was made known I was Mike Clarke's brother it was like having a license to or say any thing, I was accepted. I was one of the boys. I recalled the times my brother had told me of the parties they use to have and I began to want to get involved in all the fun. Pep pills, scooters, Mod fashions, dances, girls and permissive sex. All of which I found positive and attractive as we were looking for a good time in the world.

The image I had of my brother was that he was quite a character and had a way with girls. I remember that was how I wanted to be and follow him in fame. I remember one impressive occasion I must have been just 16 and met one of Michael's friends who was a Mod. One Saturday night out side the Grosvenor he came dressed in brightly coloured trousers and a black plastic mac wearing girls make up around the eyes. This was the in thing to do and I thought this is good and liked it.

The normal mode of transport was either a Lambretta or Vespa scooter with crash bars, back rests, spare wheel carriers and mirrors. The scooters would be custom sprayed and generally a world war green Parker or black plastic cape was the uniform. All of this became the world I wanted to be in.

Oxford Bags

I remember my brother coming to see us at Rockley Sands, in Bournemouth when I was away with my parents on holiday. I must have been 15 years old. He came dressed in a brown suit with 22 inch, Oxford Bag trousers, with small turn-ups. His top was a white crew necked and red stripped tea shirt. Also brown brogue leather shoes. This was some fashion that I had not seen before. It was the Mod fashion.

He told me he had to return to Aylesbury to do some repairs and tidy up mum and dads house as they had a party and the place had been wrecked. Apparently all the Aylesbury Mods and from the district had been to his party held at Mum and Dads house. They had rolled up the carpets and put

them in the garage but the bathroom sink had been pulled off the wall as some girl had got drunk and sat in it. He told me of the promiscuity and it all seemed good fun. This was the year 1963 or 4 when the Beatles and Rolling Stone came to fame. Also Gerry and the Pacemakers had a hit records at the time called, "I Like it".

My First Girl Friend

I met Susan, at a Friday night dance being organized at the Aylesbury College; she was 15 years old and looked great. She had blond hair in a Bob style. I was 16, wearing my navy blue Mod suit. I had arrived on my Lambretta.

I asked her to dance and later asked if I could take her home. I was feeling great when she agreed and so I covered up my learner plate, which was just under the rear, number plate and took her home. This was the beginning of my first love. The relationship only lasted a few months. When she told me she wanted to finish the relationship I was heart broken and she sought to encourage me by saying I would find some one else. I never did and had no interest in finding any one else. My only interest in girls after that was for sex alone- not friendship or anything else.

Another Who song that expressed my emotions at that time and I first heard this at Borehamwood.

The Mod Image



Lambretta Scooter Blond Girl Friend Sue

During this time Malcolm and I mixed with the Mods in Aylesbury we were both 16 years old and we began to meet with these older lads and were curious to try pep pills (purple hearts, black bombers and Dexedrine) and smoke hashish, or grass, so we began to make some inquiries where to get some. In the mean time we would experiment smoking crushed co-deine tablets and dried banana skins. This was purely to satisfy a curiosity and to experience new things. There was a pub in Aylesbury called the, "Flee Pit" situated in Kingsbury Square and it was there we understood we could buy hash. However at 16 years old I went in this pub and became very em-

barrassed as on the wall behind the bar were displayed ladies knickers in various styles and colours. I felt embarrassed because the sight aroused me as at that time there was very little pornography and the sight of a woman in a short skirt and legs was very provocative for a 16 year old, On reflection I had a very high libido. Which led to a very promiscuous life style.

Carknapping (Steeling Cars)

Shortly after this I remember my brother coming home about 9.30 pm in a hurry. He had not long been released from Detention Centre. Our parents were away and I had a girl friend there. In came my brother and told me of his narrow escape from the police. About six of his friends had been out in a stolen car, not taxed or insured, when the police had stopped them along the Tring Road. They had all jumped out and made a run for it. It was soon after this that my brother got sent to Borstal Training for some crime or other. Never the less it all seemed a good life style and I wanted more of it.

I had discovered I could buy chloroform from a chemist and this was much better than sniffing carbon Tetrachloride or the glue substances people began to experiment with. Shortly after this Malcolm Kirkham, after trying something like, this took it in his head that he could fly on his scooter. He broke his arm and smashed his scooter in the process but fortunately not his head as he was wearing a dear stalker crash helmet he had stolen a few days before.

The names of some of the lads we knew and come to mind were: Stuart Knight, Keith Guntrip, Ian Wilton, Dill Dorwick, and Terry Tatem (Now dead), Phil Davis, Brian Collier, Mickey Coil, Roy Miles, John James, Dave King, Jimmy Findlay, Phil Davis, and the like all of which had one thing in common. They wanted fun and were the lads of Aylesbury. (Time of writing this is the year, 2000).

My Lambretta Scooter



Lambretta TV 175 CC

At that time after being sacked from the group we began going to a nightclub called the Banbury Gaff. Here we would stay up all night taking pep pills (we use to say getting blocked) dancing and talking and in the morning end up in a cafe eating toast before driving back to Aylesbury. Soon after this Malcolm began to mix with the lads from Oxford and he was later sentence to some time in prison, for some crime or other. During this time my brother was in Borstal and at the Gaff I met Alan Dodd. He was my brother's partner in crime and had escaped from Borstal and was living on a barge in Oxford. He told me at the time he had a gun and all this type of living impressed me as it seemed rather exciting. We would spend time at the Gaff talking with other lads about the crimes we had done and planned various schemes and bragged and boasted about things we had done.

From this experience of mine I can say that there is no prevention or cure from this kind of criminal mind set. Once on that route you are on the road to serious crime, as all that I knew at that time will confirm. I can also say that a girl friend could really help some one like that avoid getting into too much crime.

The Great Train Robbery

It wasn't long after the Great Train Robbery that we were finding our feet as criminals.

Brigado Bridge



The Scene of the Robbery 1963

The great train robbery had taken place on August 8, 1963 at the Brigado Bridge in Linslade, just up the road from us in Aylesbury. The thieves laid an ambush for the mail train running from Glasgow to Euston and stole more than £2 million. For 125 years, the train had run uninterrupted until that night, when it was stopped by a red light in Buckinghamshire. Bruce Reynolds who crafted the robbery, was caught in 1969 and sentenced to 10 years in jail.

We were very impressed at this crime.

The Kray Twins

In the 1960's, the Ronnie and Reggie Kray were seen as prosperous and charming celebrity nightclub owners and were part of the Swinging London scene. A large part of their fame was due to their non-criminal activities as popular figures on the celebrity circuit, being photographed by David Bailey on more than one occasion; and socializing with lords, MP's, socialites and show business characters such as the actors George Raft, Judy Garland, Diana Dors, Barbara Windsor and singer Frank Sinatra.

“They were the best years of our lives. They called them the swinging sixties. The Beatles and the Rolling Stones were rulers of pop music, Carnaby Street ruled the fashion world... and me and my brother ruled London. We were fucking untouchable...” – Ronnie Kray, in his autobiographical book, *My Story*.

The Twins



Ronnie and Reggie Kray

Kray's Imprisonment

On 8 May 1968, the Kray's and 15 other members of their firm were arrested. Many witnesses came forward now that the Kray's' reign of intimidation was over, and it was relatively easy to gain a conviction.

The Kray's and 14 others were convicted, with one member of the firm being acquitted. One of the firm members that provided a lot of the information to the police was arrested yet only for a short period.

Out of the 17 official firm members, 16 were arrested and convicted.

The twins' defence, under their counsel John Platts-mills, QC, consisted of flat denials of all charges and the discrediting of witnesses by pointing out their criminal past. The judge, Mr Justice Melford Stevenson said: "In my view, society has earned a rest from your activities." Both were sentenced to life imprisonment, with a non-parole period of 30 years for the murders of Cornell and Mcvitie, the longest sentences ever passed at the Old Bailey, (Central Criminal Court, London) for murder. Their brother Charlie was jailed for 10 years for his part in the murders.

Mods Scooters, Bikes Bubble Car

Shortly after my brother came out of Borstal a form of transport was required for two. A solution to this came through my brother who persuaded me to swap my scooter for a two-seater, Issetta 350 cc bubble car. I had inherited the scooter from my Michael when he was sent to Borstal but by now it had been renovated. I had rebuilt it in the spare bedroom at home and re sprayed it British racing Green. It was a Lambretta T.V. 175 cc. The fuel tank and tool compartment was stove enamelled gold. It had a dual seat with a passenger back rest with very little extras. There had been crazes whereby crash bars, wing mirrors, wheel racks and anything made of chrome were generally attached to such machines, but not mine. I was proud of this Lambretta. It had to go to make way for the sky blue Bubble Car.

Pete Townsend Gives Us A lift

Before this time we had to thumb lifts, to get to where we wanted too if the scooter was out of action. On one occasion we were keen to get to Bedford, as The Who were playing at the Corn Exchange. We were dressed in our Mod mohair suits and carried a small suitcase with our night things in. We got as far as Ampthill and were stuck at the corner of the Ampthill to Bedford road and were about 20 miles from Bedford. We were stuck and Michael went into a pub to get a drink whilst I stayed on the corner trying to thumb a lift as my brother needed a lift as well. To my relief and just after Michael had gone to the pub, a two seater red coupe Jaguar pulled up to offer me a lift. I rushed up to the window of the car, carrying our small suitcase, feeling very relieved that I had a lift, but at the same time anxious as my brother was still in the pub. I said to the driver cheekily would he mind waiting a minute, The driver was fine and said OK. However to my surprise and amazement I realized whom the driver was it was Pete Townsend, the lead guitarist of The Who. Of course that made our day. By this time Michael had arrived and we both squeeze into the front seat of Pete's Jaguar. We told him who we were and that we were off to Bedford to their gig at the Corn Exchange.

As we drove into Bedford we stopped and Pete asked me to ask some girls the directions to where The Who were playing. Sure enough they knew and pointed us in the direction of the Corn Exchange. It was a great evening.

Pete Townsend's Jaguar



Pete Townsend MK1 Jaguar

9 The Bubble Car

The bubble car belonged to David Ness of Chiltern avenue in Aylesbury, who had been given it by his brother. There was only one thing wrong with it. We had to bump start it as the starter motor did not work. (Push it and the put it in gear and jump in once the engine had started).



Front Loader 300 BMW Issetta Bubble Car

In this vehicle we had many adventures because we were liberated from the two-wheeled scooter and could cram four people in this vehicle, if we wanted. Neither of us had passed our driving test to drive a normal car but I had passed my test to drive a motorbike and my license allowed me to drive the three-wheeler bubble car. We were able to carry blankets spare clothing etc. all in the dry. We carried all that we needed for a night out in that case. It was ideal for catching girls. The front opened up and it could be driven with the front door open. All we did was drive up to the bird we wanted to catch and stop in front of her. Open up the door and drive forward. She had no option but to fall in and we would drive off with her in the car. It was questioned was any girl safe with us around.

Dr Clarke's Case

Whilst Michael was in Borstal, he had made for me a wooden case, like a brief case, that he had written on the side, Dr Clarke. This was for a bit of fun. However I carried, in that case, a bottle of Chloroform, whiskey and a fake gun (it was a starter pistol that fired blanks and looked real). We used the case to frighten people, as they soon learned what was inside the case.



Dr Clarke Case

On one occasion we went into the Crombie shop, just off Kingsbury Square intending to frighten the manager of the shop.

What had happened was that I had a blue mohair navy suit made to measure by him. However the jacket did not fit right and even after many alterations it did not fit properly. This was whilst Michael was in Borstal. So on Michael's release, and him hearing about the suit, we decided to go and get our own back and frighten the manager to pieces. He was about 21 years old and we were younger. So we went into the shop and put Dr Clarke's case on the counter and proceeded to get the chloroform out of the case intending to put the manager to sleep. We had no other intentions but simply to frighten him. When he realised what was about to take place, he was terrified and I had to stop Michael from knocking him out with the Chloroform. On one occasion we set off to Margate, on one Bank holiday. This was a custom amongst our generation of Mods. We all seemed to migrate to Yarmouth, Margate or Brighton. This was Whitsun bank holiday.

Off To Margate

1966 and Mod and Rocker riots were common. On this trip to the coast my brother was true to form he had borrowed a 22 Webley air pistol from Pat Jones and was determined to have a good time. He had fired the occasional pop shot at one or two girl's bottoms, which cause many amusements to us all. This was not what I would have normally done because I remember how shocked I was at 11 years old a boy I recalled boys having air gun fights in the woods on the way home from school. I thought then how dangerous and stupid it was. However her was my brother older than I acting fearlessly. I just went along with it suppressing my natural cautiousness.

As we past through the various towns in London the air pistol was used to cause alarm. (As I write I shrivel up at the thought of what was done) We found it amusing to shoot at ladies bottoms as their reactions of shock was funny. As we passed through Lewisham several people must have reported

the mystery air gun shooter and at least one lady was wounded.

Caught By The Police

Traffic police on route to Margate stopped us. These men briefly searched our car but found nothing suspicious and let us go. My brother had hidden the pistol just in time and we did not allow this close shave stop our adventure. Persons (girls) bathing at night were targets for our folly and we found it amusing to see and her scream from a female. It was not intended to wound or harm but that really was inevitable.

Our BMW Bubble Car



300 CC Bubble Car

During this weekend we moved on to Ramsgate and again moved with a spirit of naughtiness decided to steel a tray of peaches from a fruit and vegetable shop. The bubble car was to be used as the get away car. The shop was half way down a hill with houses on either side of the road, it was decided I should take the peaches and my brother to drive the get away car. I lifted the tray of peaches and jumped in the car as it rolled down the hill making a chug, chug, noise-attracting attention. Naturally we were spotted and reports were made to the police but we did not know this.

Our foolishness was brought to an end when the same traffic police that had stopped us in London, on the way home, picked us up. I could tell from their faces that they had it in for us.

A quick search of our vehicle revealed a stolen handbag. If only we had got rid of it, I thought. Then the air gun pellets and finally the air gun itself. That was it we were arrested, the policemen having a snarl on his face and almost laughing at us. We were charged with malicious wounding and two cases of stealing. A woman in Lewisham had been travelling in a side car and been hit in the neck by the air pistol by my brother.

I was granted bail but my brother detained in custody. We had decided that I would say I had done the shooting and my brother was a sleep. This was to get my brother off a prison sentence as he had already done two spells in Detention Centres and two years in Borstal. I had only had a probation order and had an apprenticeship. I thought I would only get a fine but I was wrong.

Our Mum managed to obtain bail for my brother and we appeared in Kent Quarter sessions several months later.

On recollection I can remember a prison officer, at the Rochester Borstal, where I had visited my brother a year previously, had said to me that I would be sent to Borstal if I didn't watch out. I said, "You must be joking". I was sent to Borstal just as he said I would be for confessing to this crime. We were charged with malicious wounding.

On reflection I think my brother was not being a good brother to me. He should not have let me do it.

Bubble Car Blows Up

During the time we were awaiting our court appearance we went one night to Bedford in the bubble car. On the way home the bobble car caught light and blew up as the petrol tank was above the engine. We managed to walk to Woburn Green and decided we would have to sleep the night there. After routing through some ones garage we found an old mattress and blankets and there was a newly piled mound of grass on the village green. This was where we made our bed and it was very comfortable. We put up our umbrella that we had rescued from the bubble car and slept soundly until the morning. The police, who wanted to know what we were doing - as if they could not see, waked us up. When we explained the bubble car had blown up they said oh yes they had seen it up the road. So they let us go without any further questions. I arrived at work that morning but was soon to be dismissed because I was due to appear in court and they were not prepared to trust me any more. This was the last of the bubble car as my parents managed to sell it when we were in prison.

I Get The Sack

Once my boss Mr Sale found out I had been caught by the police he gave me the sack and so I had no job and was about to appear in court on charges of malicious wounding and carrying a fire arm without a license. So in revenge I had a plan. I knew where the money and the takings of the shop were stored over night.

Plan A Break In

So shortly after this I instructed my apprentice, Pat Jones, to break into the shop where I used to work and had been given the sack, and he was to

take the money.

The Shop



Shop Front High Street

The Break In

His task was to climb on top of the garage roof, lift the tiles off the roof of the shop and break through into the loft, and then the ceiling. Go into the rear toilet and take the money. A great plan so we thought Then only trouble was that the money bag had not been placed in the spot that I instructed Pat to go to. So he did the job, did not get caught but we got no money..

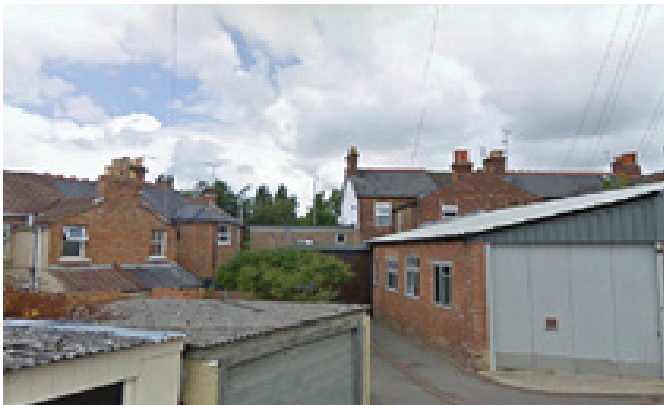

Sale And Mellor Shop Rear

The Fire Arm



The Offending Weapon

10 Canterbury Prison

When my brother appeared in the Kent Quarter Sessions court I pleaded guilty to the charges of malicious wounding and carrying a fire arm without a license and my brother pleaded not guilty on all accounts.

I was sentenced to Borstal Training, which meant I could do any time between 6 months to two years. That would depend on me to some degree on how I behaved.

Canterbury Prison together

My brother was detained in custody until he appeared in court a month later during, which time we were both detained in. Our time in Canterbury Prison was in one sense a time of continuous fun and just another of our good times together, even though I had just received an awful sentence. Upon arrival at Canterbury Prison we were taken into the reception hall. Here we were with other newly sentenced young persons and being with my brother made it that much easier for me, and it gave me confidence because he had been to Rochester Borstal, and Detention Centre on two occasions, before and he knew the ropes. Canterbury Prison

Canterbury Prison in Kent

This housed young persons who must have been typical of the criminal population of England at the time. In this prison we shared our experiences with others who had been sentenced to three, four and six months, and many had already been to approved schools, detention centres and Borstal before. Some were on their second or even third visit to prison. There was an element of excitement and curiosity about what made people like they were?

In the reception hall we were issued with prison clothing. Our fingerprints were taken and photographed and we were each given a number. After this the medical officer (all prison officers were called screws) had inspected us

and we were taken to our cell (called a Peter). At that time we were three's up. My brother and I and a lad from Liverpool. In this cell we were to remain for a few days until we were issued work. The cell was approximately 12 foot by 9 foot and housed a bunk bed and a single bed. A table, chair, water jug and urinal pot.

Canterbury Prison



Canterbury Prison Gates

At half past six each morning our sleep was broken with a bang on the door and words saying "Slop out". This meant we had to get up make up our beds and empty the urinal pot. We then could get hot water for a wash in a jug for a shave and return to our cell. A razor blade was issued and collected after and then we were banged up until breakfast.

At breakfast time we were unlocked and had to line up in single file to collect our food. This was served up on a specially shaped metal tray, which was recessed in three places to retain the food.

A typical breakfast would be a scoop of porridge, four slices of bread, a knob of margarine, a sausage or piece of bacon with beans and a large mug of tea.

The bread dipped in porridge became one of my favourite meals but on one occasion this practice of dipping bread in my porridge offended one inmate (when I was in Dover Borstal) he expressed he thought what I was doing was a disgusting habit. I just ignored him with contempt.

One of the ways we past time, when locked up in the cell, was to play "Blind Mans Buff". One of us would be blindfolded whilst the other two crept about and hid from the other, while the blind man tried to catch the others. There were all sorts of places to hide in such a small cell. We enjoyed this game we would jump from bed to bed which made the game that much more fun.

During this time I found time killing boring so I tried to read one or two books. The books I found I could read were James Bond as these were

about my level and the Beano and Dandy comics. Any other reading would be too difficult to me.

On the days we were not working, each morning and afternoon was exercise. This was where all the inmates walked as a body around the prison yard. No doubt each prisoner looked at the high walls and every building looking for a possible way to escape. During this time we could talk with whom we pleased, those that attempted an escape were made to wear yellow patches so they could be spotted easily. These times became a time of communication and formed the prison grape vine

Hair Style Change

On one occasion I decided to change my hairstyle. So during the wash period my brother removed the safety edge from the Government Issue razor and was able to shave my head. It was much easier to wash in the mornings with no hair and much fresher. However I had gone against the prison rules and was put on a Governors report and put in solitary confinement for a period of time.

At the meal time it cause an amusing stir and I was to get laughed at when one of the cooks slapped a handful of strawberry jam on my bald head. After this when my hair grew a little I was able to razor a parting in my hair which was really the beginning of the hair fashions for the skin head.

What Sentence Have You Got?

I could not help but notice the various characters and the first points of conversation were “What sentence had you got and what was your crime, or crimes”. After this an inquiry would be made as to your previous convictions and prison sentencing.

Our time at Canterbury came to an end when my brother was found guilty and was sentence to two years prison at the Kent Crown Court.

I was a witness at his trial and was detained in the cells below the courtroom. When my brother was brought below, handcuffed to a prison officer, I was shocked and disappointed that he had been found guilty. In fact all our plans had come to nothing and I was to do a stretch in Borstal. He was found guilty of malicious wounding as well and was sentenced to 2-year prison.

On that occasion my mother was not allowed to see either of us and we were taken from the cells in Kent back to Canterbury prison that dark wet night. As we approached the prison gate I saw my mum with tears in her eyes out side the prison gate. We both waved and motioned to the prison officer to say she had come to see us and his reaction was, “So what, she can’t see you because you are now prisoners”. She had not got a visiting permit. She had travelled from Kent to Canterbury late that night to try and see us

but she was rejected.

From that time we hated that prison officer called Titmouse. He was about 6 foot 7 inches tall. My brother, weeks later, after we were separated laid into this screw because of the hate. He head-butted him (nutted) and of course was on a governor's report and put in solitary confinement. This I heard through the grape vine when I was at Wormwood scrubs awaiting my allocation to Dover Borstal.

Wormwood Scrubs

I was moved from Canterbury Prison to Wormwood Scrubs in London, which was a Borstal allocation centre. After a period of four weeks it was decided I was to go to Dover Borstal. A closed Borstal called the Citadel. For the first time I was on my own and was moved from one cell to another having to share some times with others. I did not really enjoy things here, as it was lonely being on my own.

The Scrubs



Wormwood Scrubs

Dover Borstal (The Citadel)

We were allowed to go to church on a Sunday, which I did to break the monotony. However I remember being horrified by the fact that I saw some inmate tearing pages out of the bible to role cigarettes. This was probably the first sense of me acknowledging the existence or fear of God.

When at Dover Borstal I was placed in an open dormitory with five other lads. Here I had to learn to survive. There was a 6 foot 6 inch Lad nicked named Te Oh who was bullied mercilessly by a 5 foot 6 spectacled bottle job, called Vince Bowker. I saw this bullying the moment I arrived and Te oh was made to do this, do that, and he would say yes Vince, no Vince and so one hoping to get off lightly. In the end Te oh turned and lashed out on Vince Bowker and that put stopped to that. I was determined I was not going

to let that happen to me. I stood my own ground whenever I sensed any one trying to bully me. I was in fact nick named Flash Clarke because I had all kinds of goodies like, cocoa, coffee, milk and sugar and even Ovaltine and had one of the senior green ties make me Ovaltine in the morning.

Borstal Boy

One bully, 6 footer, was moved into our dormitory because he had mercilessly bullied another inmate. We got on well until I tied his shoelaces together one morning for a joke but he didn't see it that way. When he realized who it was that did it he threw these tied shoes at me in anger and this gave me a black eye. As he came at me to hit me I was quick enough to hit him on the jaw bringing him down to the ground. After that he kept out of my way and the screw that could see my black eye ignored it. I think they must have known how to deal with bullies.

Electrical Installation Course

Whilst at Dover I went on a six months training course doing Electrical Installations and I worked really hard obtaining top marks every week and I use to be rewarded half an ounce of tobacco for coming top of the class. I traded this with an inmate for his ration of milk each morning and cornflakes and an egg each Sunday morning.

We had to attend church on a Sunday and were would be marched to church in whatever the weather. We would have to be dressed in our best gear after Sunday morning inspection. I remember I had no sense of respect for God or anything like that. In fact when the vicar Rev. Whally took us for talks before we were to leave Borstal I can remember ridiculing him in front of all the inmates. I thought it was a huge joke.

Dover Borstal



Dover Borstal (The Citadel)

Paternity Suite

Whilst serving my time in Borstal I was served with a summons to appear in court to answer a paternity suit. A former girl friend was pregnant and I presume the Social Services had made her declare whom the father of the child was in order to get the finances but I am not sure as I never spoke to her about it. In fact I do not remember knowing anything about it until I had to appear in court. The first time in court I admitted I was the father because I could have been even though I knew she had been with other men. At the time I was ordered to pay maintenance out of my three shillings and six pence a week, at the rate of one shilling and three pence per week. I had no idea of the serious nature of being a father or bringing up children or any idea of taking responsibility for my actions.

My mother however was very anxious and after listening to the evidence given by the girl, she maintained it was not possible for me to be the father, as the timing of the events did not fit. She encouraged me to appeal and she really fought the case for me. This I did and with the aid of a Solicitor the girl had to prove I was the father of the child. When I look back it must have been humiliating for the girl because she had to explain when and where these events took place. My defence solicitor asked where the event or events took place. With incredulity he questioned her how could things take place in a bubble car, in the daylight. This I think on reflection was humiliating for her.

The suit was not proven and I was released from the charge. My probation officer Mr Moorland Hughes asked me many years later, when I became a Christian and had to appear in court over my confessions to many crimes, "Was I the father of the child", I replied I might have been.

The child was called David and my mother says he had ginger hair. She had seen him out with his mother in Aylesbury whilst I was still in Borstal. He must be around 33 years old now.

I met all kinds of lads here in Borstal, car thieves, burglars, forgers, and gamblers. None of us had any idea for the reason of our existence but were probably looking for the best in life never finding it.

When I was released I was determined to have a good time. I wanted the best clothes, a good car, a speedboat, and a caravan. You name it I wanted all these things and intended to obtain them by one means or another. I had learned many criminal ways and had no intention going straight. I just had no intention of getting caught at any crime I may choose to be involved in.

11 My Release From Borstal

I was released from Borstal a year later and it was during this time I

began to get into all kinds of things and criminal activities in Aylesbury.

My Gold Mini



My First Car 850 CC Mini

I bought my first real car for £100 when I came out of Borstal. It was a gold mini 850 cc.

I decided to visit my brother who was now in Maidstone Prison and I visited him when I could. Whilst he was there he met an inmate senior man from Cyprus who told him some fantastic story, which we both believed. We had ideas of being involved in gold smuggling.

It led to my brother absconding from prison and being on the run from the law for a year. He was offering us the opportunity to make money by smuggling gold. The idea was we had to pretend to be just married, we would have a suitable partner and we would carry the gold strapped under our clothes making out we were newly weds. This would reduce the chances of being stopped by customs and so get the gold through. We were prepared to take the risk. It sounded exciting and that was what I wanted.

The plan was that when my brother came out on home leave we he would go to Greece. We had to a contact in London all set up by the Greek man and take it from there. We were all hyped up but the was no such person or arrangements and we felt really let down.

However my brother decided he could not face going back to prison so he just did not return. He changed his name to Kenny? And managed to stay away from the police for a whole year before being picked up whilst working on a building site in Aylesbury.

At this time I was doing a Government training course in Enfield Middlesex and Michael got some work with a shop filling company and worked in London. He decided he would live above the shop, which was near Kings Cross, where they were working and so I was able visit him

during the week.

For a bit of fun one morning we decided to go to the cafe down the road dressing in our pyjamas and dressing gowns bringing with us our own cornflakes. We went into the shop and asked for breakfast bowls and milk and sugar. This seemed a funny thing to do and it all went down well.

Michael soon got fed up being there on his own so he decided he was leaving.

So one night we took all the companies tools and equipment and returned to Aylesbury where our parents lived.

During this time I renewed friendship with Pat Jones and we did many things together. My brother had got a girlfriend now and I was seeking to have a good time.

On one occasion I showed Pat Jones the powerful effect of chloroform and knocked him out so he was unconscious. Moved by my strange sense of humour I cut several chunks of hair from his head and when he came too he had no idea what I had done. I found it great fun when I took him home and saw his mother's face. Of course he had no idea what she was upset about. I just left and got out of the way laughing to my self.

It was after this that Pat Jones got the first skinhead hair cut in Aylesbury. No one would normally cut all their hair off it just was not yet fashionable. He did it and I was proud of him. I am sure he set the trend of the Skinhead fashion.

Mods, Skinheads, Greasers at Yarmouth

On one bank holiday weekend in 1969, when I was working for Radio Rentals in Hemel Hempstead, Pat Jones and I decided to go to Yarmouth and meet with the Aylesbury Mods, later called skinheads.

I took my firms Ford van in which we would sleep the night. On this particular weekend I was sleeping in the back of the Ford van that Sunday afternoon and Pat Jones was out with some of the lads. They had a run in with a crowd of Greasers.

Greasers were motor bikers who would fight with knives and motorbike chains. It was a very similar to the Mods and rockers you see in The Who film Quadrophenia. They were the sworn enemies of skinheads.

Mods On a Bank Holiday Weekend



Mods at Margate and

News Reports

This company of Greasers had come across Pat Jones and his crowd when out on the sea front in Yarmouth and they were combing the area for skinheads, to pick a fight with. There were too many of them and Pat Jones and the crowd was on the run and I was happily asleep in the back of the van quite safe. Or I would have been had not Pat Jones came running up to the van shouting and screaming to get out and run or do some thing. He ran off just having just called attention to these Greasers. As I looked up and came too and looked out of the van window I could see a crowd of Greasers grinning and running towards the van. They knew they now had a victim in a van. I was concerned it was the firms van so had to get away. There wasn't much I could do so I locked the doors quickly and jumped into the driver's seat hoping to drive. Unfortunately I was awkwardly parked. As I tried to start the engine a great whack came from the roof of the van. The van was hit a number of times with motorbike chains and I heard shouts of glee. Then they began to rock the van seeking to turn it over. They lifted it and rocked it as I tried to drive forward then backwards. I must have hit one or two as I managed to gut get away in time for a beating. That was all thanks to Pat Jones!

This how ever was all part of our fun getting into scrapes of one kind or another. On the way home that week end we decided to tow a four wheeled sea side bike back to Aylesbury so I got Pat Jones to ride the bike whilst we towed this bike all the way from Yarmouth to the outskirts of Norwich before deciding to lead it outside a pub as I began to realize we would be captured by the police going through London. It was all good fun and it made us laugh.

Newquay Here We Come

It was the summer of 1968, shortly after my brother had been released from prison and I had served time in Borstal. We had decided to go on a holiday, seeking the sun.

Our Holiday to Newquay



Newquay The Place Of The Sun

He had become friendly with a girl called Karen Mead but that did not stop our plans. We were going to go off with no plans to return. Michael had a nice long wheeled base Bedford van. This was fitted out with our equipment to live and we fitted a double mattress on the roof with a tarpaulin like tent. This was to be our sleeping arrangements.

It was decided we would make our way to Newquay in Cornwall as I remembered going there with my parents when I was 16 years old. That year the sun was hot, the surfing was good and a really nice summer. We were off to seek the sun.

Our Bedford Van



This is where we slept for 6 weeks

Our first mischief that we planned but fail to do was the stealing of a speedboat, moored in the water at Barnstable. That evening we had planned to swim out to the boat and cut its moorings and float it down river to load on a trailer. That after noon we borrowed tools from a workshop and got some welding done to make a tow bar for the van. We needed a tow hitch to drive away with the stolen speedboat and trailer that night.

All went to plan until that night when we got the trailer ready but when we looked at the cold dark water, it being pitch black, we both lost our bottle and decided to call it off. We left Barnstable disappointed

The Beatles Magical Mystery Tour

I had been to Newquay before and I told Michael all about it. It was the place to go for surfing and to seek the sun. The Beatles had been there before us and stayed at the Atlantic Hotel and were filming their notable film *Magical Mystery Tour*. The Beatles stayed at the Atlantic Hotel in Newquay. They booked into The Atlantic Hotel in Newquay on Tuesday 12 September 1967 and left on Friday 15th. Newquay was a famous place to go on holiday and we knew why.

Our Holiday A Place of the Sun

Our first mischief that we planned but fail to do was the stealing of a speedboat, moored in the water at Barnstable. That evening we had planned to swim out to the boat and cut its moorings and float it down river to load on a trailer. That after noon we borrowed tools from a workshop and got some welding done to make a tow bar for the van. We needed a tow hitch to drive away with the stolen speedboat and trailer that night.

The Atlantic Hotel Newquay



The Atlantic Hotel Where The Beatles Stayed

All went to plan until that night when we got the trailer ready but when we looked at the cold dark water, it being pitch black, we both lost our bottle and decided to call it off. We left Barnstable disappointed..

I Am A Waiter At The Gull Rock Hotel

Our first bit of work, which we did, was to work in “The Gull Rock Hotel” in Newquay. I was a waiter and my brother was a kitchen porter. I had never been a waiter before but soon picked it up.

We were given sleeping quarters but we soon realized this kind of work and life was not what we wanted. The hours were unsociable hours. So the next morning we decided not to go to work, just stay in bed. We made a huge joke of it and expected to get the sack.

Sure enough we were knocked up when it was realized we were late but still we did not surface. When we decided to get up we went to the chef believing we had got the sack and so to collect or pay. To my surprise they hadn’t sacked us but had just thought we had too much to drink the night

before and were prepared to overlook the sleep in. I said no we would leave and we each got the £1 each we had earned for the day's work.

In our mischief we went back to the sleeping quarters the next day where the girls were sleeping and jumped into bed with two of the girls. They didn't want this really and made a bit of a protest but before we left the manager's wife had been informed and came to see what was happening. As she came into the bedroom we were seen in bed with Angela the chambermaid. The manageress screamed, "Oh! Angela how could you". The girl got the sack and I felt really bad about that afterwards.

Shortly after this we decided to rob a petrol station to get some money. My brother tried to disguise himself by wearing a long girls wig but this made him stand out even more because he was flat chested and had no hips like a woman and this attracted attention rather than do the opposite. That idea was discarded so I decided I would take the money. When the attendant was looking after a motorist I crept up to the till and took the notes and ran away behind some building. Then quickly dressed in an old overall coat and then walked slowly away without being noticed.

We Return Home To Aylesbury

In the end I noticed my brother writing to his girl friend and somehow we decided to return home to Aylesbury.

After this I began to spend time with Pat Jones as my brother got more involved with his girl friend. Pat Jones and I got into all kinds of things, which I will mention later on. I was 20 years old and he was just 16 years so he began to learn many things off me, all which was probably bad for him.

It was after this I managed to get a job with Radio Rentals in Hemel Hempstead

This was a good job and at 20 years old I was the only Colour TV Engineer in the Hemel Hempstead branch and with a company car.

Our Trip To Shoreham

About this time we went on a sailing trip to Shoreham near Brighton. This weekend we were invited to go sailing with Ken and Grace Knight. I took Mary Bilton a girl friend of mine, Bernie Gilbert and Alison Knight. Whilst we were there Mrs.. (Grace) Knight went off to stay with a Christian friend in Brighton. Not that I knew that at the time I just thought she did not like sailing and it was a Sunday and she wanted to go to church.

The History Of The Jews And 1967

We were all invited back to this Christian man's home. He was called Tom and was a manager of an insurance company in Brighton. That afternoon he sat and talked to us all about the bible. I was almost convinced by his talk and began to believe there was more to the bible message than I had ever

really liked to admit before. He told us about the history of the Jews and all future events. It was all foretold in the scripture. The history of Israel was recorded and the return of the Jews to the land of Israel in 1967 was clearly a sign of the last days.

I was very impressed at what he said. So much so that I began to tell my friends at college the very next week all about it. This made me read parts in Deuteronomy about the curses that would come upon the Jews if they forsook Moses Law and reject the Lord Jesus Christ.

Pat Jones And The Bully

At this time Pat Jones was in his final year at school and he informed me of a bully who would relentlessly give him grief at school. The school was the Grange Secondary Modern School in Aylesbury. The school I had attended until June 1966.

One day at the evening youth club held at the school I decided we would sort this bully out so I instructed Pat ‘ Bones” to do as I said. I was dressed in my long Crombie over coat, which my mum had altered for me, and inside I kept a large long rubber torch, which was ideal for use as a cosh. Not too hard to break the skull and not too soft to do no harm. Just about right to knock some one on the head and possibly knock them out.

This was the plan. We were to go to the youth club and search out this bully. The Grange youth club was held behind the school buildings in some prefabricated buildings. It was early evening and not too dark and a few people were around. Here we looked out for the bully.

I gave Pat Jones the large heavy rubber torch and said to him when he sees the bully he must call out to him, “ Come here” and walk towards him. When he came right up close he was to shout at him the words, “ I have had enough of your nonsense and if you don’t watch out I am going to set Dave Clarke on to you”. He was then to point in the direction away from him so as to make him turn around and say’ “ look he is over there”. When he turned around he was to hit him on the head, as hard as he could with the torch. Then say, “ Now I am going to do it again and roar at him.

The plan went perfectly. We saw the bully dressed in a Denhim Jean jacket he had slight ginger hair. I am sure his nickname was Ginger) .I had never met him before. Pat Jones shouted out to him and sure enough the bully came walking like a gorilla with his arms swinging by his side. Almost running to get at Pat Jones eager to get him. I was happy because this was where he was going to get the treatment. Pat did exactly as instructed. He said look over there and as he turned around Pat walloped this bully hard on the head. Every eye was on the two in conflict. The bully was stunned and his hands went up to his head to hold it as it hurt. Then Pat shouted at him to

say he was going to give it to him again and sure enough the bully ran away as predicted. I encouraged Pat to chase after him to make sure he now knew his place. Every one looking on looked in amazement.

From that day forward Pat Jones had no more trouble from that bully. I felt quite satisfied in dealing this way with the bully.

How would Jesus have us deal with bullies today? This is a real problem to parents in a world of violence like to day. I was not a Christian but this remedy actually worked in Pat Jones's case.

12 Conversion from Crime to Christ

Having worked through and experience many things I often thought about life and its meaning. I could recall the absolute emptiness of my soul after going out for the evening and coming home. All was empty and what was the point to it all. I was seeking an answer to life, the universe and every thing.

A Bad LSD Trip

The following is an account, taken from memory and notes made of my experience of conversion to Jesus Christ on Friday, 16th January 1970.

Towards the end of 1969 I was continuing my studies at Luton College learning Radio and Television Servicing. We would often engage in discussions and it was quite easy to divert our lecturer onto subjects like spiritualism and the like. We would discuss what we would do if another world war came. We would talk about the future as portrayed by Nostradamus, drugs and our experiences. At that time I was informed of a new film called Easy Rider and wanted to see it. On one occasion I obtained some hashish mixed with opium and smoked this during our break time. This was so effectual I made use of the sick room at college to sleep and enjoy the illusionary effects of the drug, which amused my student friends.

On another occasion in January 1970 I had obtained 4 tablets of LSD from Peter Coppenhall, a student friend from Bedford, he was one of my fellow students at Luton College, and I decided to take them the following Friday night 16th January 1970

On this Friday night the 16th of January my brother I decided to each took half a tablet and Pat Jones had a quarter. He had been a close friend of mine (he was only just 16 years old) for some time and I use to think of him as my apprentice. I taught him all my bad ways. There was little we did not do together. I had known him whilst he was at school and encouraged him in crime, sniffing chloroform, smoking (marijuana, hashish, weed etc.) drunkenness, violence and permissive sex. He was known amongst our friends as "Bones", Patrick Bones.

My brother was going out that night with his girl friend Karen Mead so Pat Jones and I decided to walk up town and not risk driving for we did not know the effect this drug would have on us. I was dressed in my old clothes deliberately for I did not know what might happen too us. We tried to thumb a lift but eventually caught a bus and got off at the bottom of the High Street. As we walked past the “pictures” I noticed the film “Easy Rider” was being shown so we decided to go and see it.

We wanted to take some one else with us, some one who was in their right state of mind, so we went up the billiard hall and found Bernie Gilbert and Mike Ellis but they said they would only come and watch the film with us if they too had some acid.

I decided this was OK, and so we got a taxi back to my house to get the rest of the Acid. Bernie had half a tablet and Mike Ellis the other quarter. So all four of us were about to trip on acid whilst watching the film Easy Rider. We arrived back at the “pictures” about 8.45 PM and I fumbled a bit with my ticket as the acid had begun to take effect. Bernie and Mike suggested we go and sit up in the balcony but I thought to my self, what if we decide to jump off? I was tripping now and just followed them up the stairs. We sat two in front and two behind, but Mike and Bernie’s trip had not yet begun as they acted and spoke normally.

The Film Easy Rider



Peter Fonda and Dennis Hopper

They seemed to know how to give the correct lighting and sound effects. However Bernie and Mike seemed to be jumping about all over the place and it was irritating. I still was sitting in my seat when all the people had gone, before I decided there was nothing more to do. So we decided to up and go but Mike and Bernie were annoying me because they were mucking

about.

All my thoughts and feelings began to reverberate four times over and thought patterns were being reflected and at the same time building and snowballing.

We walked outside the cinema and I said to the boys, "Man you are all on the wrong scene you can't be turned on". Then I heard Mike and Bernie say he's turned into a wizard (Hippie) and there was a club room for wizards like me (The Dark Lantern Pub in Aylesbury). I then began a downward trip, which ended in the horrors. I began to feel paranoid thinking they were now sorry for me and were being polite in hiding their feelings from me.

As we went further up the road Mike Ellis asked if I wanted a scrap with some blokes across the street. It was as if he was testing me out to see if I was the same person he knew. I said no I didn't. I thought they had thought I had gone mad and they wanted to test me out. We went further up the high street and Bernie began to mess about and pull faces at me and make noises. I hid in a shop door way and told him to stop it and Pat Jones pulled Bernie away saying don't do it as he didn't understand. My horror began when I could not face the thought that they thought I had cracked up and gone mad. This feeling was too much for me to bare. More was to come.

We decided to go to the Crown pub and Brian Sale came up to me and spoke but I was out of my mind by now with this feeling of paranoia and could not speak sensibly and came out with a load of nonsense, so I had to say quickly I was drunk because I didn't think he would understand other wise.

I then saw my Michael sitting with his girl friend and I went up to him and told him what was happening. He laughed and motioned to wine me up like a clockwork toy and then my mind began to distort so much so I had to run out of the pub to get away. Pat Jones followed me and I kept thinking the others were following us. I kept looking back as I didn't want them following me as they annoyed me. We left the Green Man and walked towards Mount Street, via Richford's Hill and along Friarage Road. On the way down it seemed like a scene from a picture book and was like Alice in Wonderland with all the street lamps lit up.

The torment of my mind had grown so much that I could not bare the pain but I could not get rid of the torment. Ken and Grace Knight lived at Mount Street. We went down there with no real aim and as I arrived just outside their house Jock Macallion, another friend of mine, was about to leave and drive off. I jumped in besides him and told him my situation. After telling him I was tripped out of my mind I was thinking he would take me home and as I was about to ask him he said, "Dave you are a worried man". I

knew this and I now though so did every one else and being told that did not help me at all. My mind was about to blow so I had to run again. I jumped out of the car and into 24 Mount Street where Ken and Grace were. I wanted to escape and so I told them my plight but I could not explain to them what was happening to me. Grace Knight recalled she thought I was in serious trouble and began to question me. This didn't help so I had to say forcefully I must have peace so they took me out to the summerhouse to lie down in peace.

No one seemed to understand the torment of mind I was in and no one could help me at all. I told Mrs. Knight to leave me alone to work it out on my own and let me lie down. Then the torment got worse. I knew it was only the LSD doing it but I could do nothing about it I would have to wait till it had taken its course. I thought it could be 12 hours or so but to me each moment seemed like an eternity of torment and I could not endure this any more.

I lay down and tried to settle my mind by thinking good thoughts and different things but my mind would not be controlled. The thought came, "I may be driven to kill myself to get rid of the pain", but I was horrified at the thought and the more I tried to stop thinking like it the more I thought about it. I looked around to see if there was a mirror or glass in the room and wanted to get rid of it just in case I cut my throat or wrists. I just did not know what to do I was at the end of my self.

In this condition it was evident I could not help myself. My friends could not help; my brother had not helped. Mr and Mrs. Knight couldn't help and I could not help myself.

In this desperation it came to me to call out to God for help. So I cried out calling on the Lords name saying, "Jesus please help me". At that moment my mind went blank and his name appeared in the imagination of my mind but the torments soon came back again. I called out again and his name appeared twice and the happening repeated. I called four times in all and his name appeared four times and formed a square in complete emptiness.

I then began to feel emotional and wept but I didn't know why and at that moment Mrs. knight came to the chalet door to see if she could help. It was then, at that, a flood of guilt overcame me. I was convicted of the sin of Adultery and did not know what to do. I beckoned Mrs. Knight to come in and said to her did she realize how bad I was and what I had done. I asked her to tell me the way what could I do.

Mrs. Knight had spoken to me about Christian things and some how I knew she knew the way. Mrs. Knight sat down and quoted the scripture saying, "For God so loved the world that he gave his only begotten son that

who so ever believed on him should not perish but have everlasting life.” (John 3 verse 16).

Dave I Am With You

After this Jesus spoke to me, I heard his voice as clearly I am writing this he said, “Dave I am with you, you have been searching for a long time, this is what our Father says. What you have been going through is nothing compared to what hell is like. I replied with thanks giving saying thank you, Jesus thank you.

Mrs. knight I think thought that I was speaking to her she but she did not know what was going on.

It seemed that the words that Mrs. Knight had spoken, were in fact the way out and pathway to my escape. It appeared as though I was at the bottom of a pyramid and the words were the way to the top and if I were to follow the words I would escape. I replied thank you Jesus thank you.

I then thought of hell and my thoughts were about the Pat Jones, Bernie Gilbert and Mike Ellis and I said what about the others. Jesus spoke again and said, “ all I could do was tell them”.

I replied feeling it an impossible thing to do to convince them ”but what more could I do” I was feeling the agony of the LSD horrors and knew I wanted to warn my friends of the hell to come. I reasoned within my self they will think I have gone mad on LSD how could I convince them, I wanted to do more than tell them. I asked what more could I do.

All I could Do Was Tell Them

In order to answer my question the Lord took me back in time to show me all I could do was tell them. A number of weeks earlier I had reason to read about the curses that were to come on the children of Israel if they forsook their God. Deut. 28 v 53. And though shall eat the fruit of thine own body. (I knew nothing about the back ground to these things) I thought it was saying people would be so hungry and having no food to eat a woman would be driven to eat her own after birth. Which of course was shocking. With this in mind these weeks earlier I was trying to shock this girl at work. I was working for Radio Rentals as a Colour TV engineer and I said to this receptionist how would she like to be so hungry to have to eat her own after birth? She responded with expected repulsion “ How could you say such a thing”. I simply said I hadn’t said it but God has. This thing repulsed her and she did not want to know anything about what I was saying (Not suppressing). However to this incident Jesus took me and asked me, “ what did the girl do when I spoke to her”? My answer was she shut her ears, as she did not want to know. It was repulsive to her. His reply was to me that, “ if I tell people about Hell and what I had learned and they screw their faces up

and do not want to know I could do no more.” The condition of the person listening is not my responsibility but theirs. All I could do was tell them. So tell them I would.

To these questions Mrs.. Knight thought I was asking her, because I was speaking aloud, but before she could answer I had been answered directly from the Lord.

When Jesus stopped speaking I felt as though I was falling back into my torment and I prayed again, “Please don’t leave me”. My reply was, “ I will never leave you”.

Why Boast

Jesus then questioned me and asked me, “Why boast”. This is because I was naturally prone to boasting amongst my friends just to make a good impression. I reason within myself now and now knew I had no need to boast of anything. So from that day I have always avoided boasting.

My torment ceased from that time and the rest of the night passed with various thoughts going through my mind. I do not think Mrs. Knight was fully aware of what had taken place.

The next day was Saturday and I was due in to work but I decided to take the day off. I phoned in briefly saying I was not up to work.

13 What after Salvation

Pat Jones had spent the night in the caravan parked at the side of the Knight’s home, together with Paddy who had no where else to live. We spent that day together and I told them both of my experience. I assumed and expected them to fully understand and see what had happened.

Instinctively things were different with me. An internal change had come about and by it I had new desires. I no longer wished to live as I had lived and wished to be rid of my bad ways. No one told me I had to give up any particular way of life, I found within me an internal desire to choose the good and refuse the evil.

Evidence of the New Birth

Upon reflection I say this was the evidence of the new birth and I later found this experience spoken of by the Lord Jesus Christ in Johns gospel. John 3. Jesus answered and said unto him, Verily, verily I say unto thee, except a man be born again, he cannot see the kingdom of God. The Apostle Paul also writes the same in Cor. 5 17. Therefore if any man were in Christ Jesus, he is a new creature: old things are past away; behold all things are become new.

I knew also there was a part of me which was just the same and when I would do good evil was also present with me. The Apostle Paul in Romans

also expressed this. Rom. 7 verse 21. I find then a law that when I would do good evil is present with me.

Whilst this was my experience I found it impossible to convey this to my friends even thou I tried ever so hard.

What To Do With Stolen Goods

I had in my possession much stolen property. In fact hundreds of pounds worth of stolen goods. I was no longer prepared to live off the benefits of stolen goods. What should I do? I had involved others in my crime of stealing and these could not help me now. In fact Mike West came to see me the next day and when he heard me explaining Jesus had spoken to me he began to fear I might go to the police and confess my crimes. I did not actually say to him I wanted him to return the Colour TV set, which I had stolen and swapped for his Citroen car but he was concerned, as he did not know what to think.

Poor Mike he must have panicked thinking I was about to go to the police, as he was concerned some of the stolen goods that I had left in his garage were a stolen including the mini engine sub chassis. I don't remember what happen to these parts but I asked Mike to dispose of them. I was later informed they had been dumped in the reservoir.

That Saturday evening both Pat and I decided to go to the Social Club at Park Street.

This was the usual thing for us to do on a Saturday night. I had determined to go and see my mates to explain what had happened to me. We walked down there but did not go in. After seeing one or two people I broke my news to them. I cannot remember what I said. I had no desire to stay so went back to the Knight's home. My inclination to live it up as normal was no longer with me. I now seemed at a loose end not knowing what next to do. From that time forward Pat Jones began to realize things had really changed for me.

The next day, being Sunday, Mrs. Knight took both Pat Jones and I to the local Baptist Church in Southcourt, in the evening. I distinctly remember the passage of scripture the preacher spoke from. It was in Exodus where the whole nation of Israel was about to enter the Promised Land. However they listened to the evil reports of the 10 spies and did not take heed to the voice of the two good spies. Who gave encouragement to go in and possess the land? I remember also I saw, whether he preached this or not, that this was a picture of the body of Christ - the church of that day.

Seek To Tell Others

After the meeting Mrs. Knight introduced me to a Martin White who gave me a copy of the New Testament called the Good News for modern

man. I began to read this straight away. This I received gratefully and began to read it every day

The following days were spent in the after glow and certainty of this new life that had opened up to me. I thirsted for knowledge, the knowledge of God in Jesus Christ. I told the folk at work about my experience and could not remain silent about the things I was learning.

Southcourt Baptists



South Court Baptist Church

My evenings were spent at Mrs. Knight's home discussing the scripture with some of her Christian friends. Both Pat Jones and Paddy all seemed interested to hear.

My own ignorance never read the Bible

I am now amazed at my own ignorance then for until then I had never read the bible for myself. I did not know what the Acts of the Apostles meant. Within two weeks I had read the New Testament and thought I understood it all. I soon learned from the scripture that in the economy of Salvation it was the blood of Jesus Christ shed on the cross at Calvary that was the means of me obtaining a free pardon for all my sins. And also that I was given freely a righteousness to justify me before God.

In this respect the Lord Jesus was a true substitute and he died for me without cost at all to me. These were the things, which I learned and as it were drank in like water from the well of salvation. I learned them by reading the scripture and did not know them from the night Jesus spoke to me.

Difference at College

I attended college that week but there was a difference. I had decided I would not dress in my usual clothes to show off. Which would have been Levi jeans, white boots with red toe caps (or whatever colour I chose to spray them), a Ben Sherman shirt and loose leather jerkin. I felt I must not only be

more sober but dress more soberly too i.e. not show off as I use to do.

So I dressed in my best trousers, which were from my Prince of Wales cheque suit, shirt and normal pull over and normal shoes. Of course I had to tell all my friends about my experience. I protested to them look I even dress differently. They could not believe me. I told one of the lecturers, Mr. Jones, in front of them all but I was just given a smile of wonder.

I Tell Rupert

That same week I felt constrained to go and tell my friend Rupert, a West Indian from Jamaica. He lived in a room, at 14 Bicester Road Aylesbury so Pat Jones and I went to see him. As soon as I met him I told him what had happened in front of his new girl friend but Rupert's reply was, "I told you Dave not to take LSD". Again they were none plus, they could not believe even though I tried my best to convince them.

Turning From The world

Being in the world but not of it. It was now wrong for me to continue in the way of life that I had lived in the past. My back was now turned from the world that I once laid hold on, and had built for myself. I was self-seeking (ones own glory), asserting self without considering others, stealing, and thoughts of adultery, fornication, drug taking, drug selling, boasting, drunkenness, violence and worldly ambition. I say worldly ambition because I believe we all have worldly ambitions but when we are converted and come to Christ we are called to forsake it; that is forsake the world and its ambitions.

We all have our own worlds to forsake when we become a Christian. Some have a religious world to turn from; as a person may have been born in a religious family or have a circle of religious friends but in their world they have their own natural fallen nature to contend with. Fallen human nature seeks to gratify its desires and as such sin the whole day long. A religious person still has all the workings of a natural man as those who have no religion. Any thought or act, which is born out of selfishness, greed, pride, avarice, thinking evil of others, back biting, slander and prejudice may all be practiced by those in a religious or none religious world. So to forsake the world means to forsake all those thoughts and actions, which are natural to us, and are contrary to the way of Christ.

Religious And None Religious Persons

Need to turn from their world

Some persons have no religion or religious friends, yet they too have natural desires and a fallen human nature, which they seek to please. Ambitions of fame for its own sake, the love of money, selfishness, the practice of gossip, evil speaking of others, are all to be turned from. It doesn't matter whether you be in a religious or none religious person we are to world are

to be forsaken the world from which we come from when we seek to follow Christ. We are called to be in the world but not of it. This is really what John Bunyan sought to express when he told his story of the man who turn his back on the city of destruction. One of the problems how ever was that his story only described the picture of those who were none religious and the pattern of their life styles. In reality a religious person, one who is not born again, has a pattern and life style, which is equally wrong and such need to be turned from. It is very easy for such a person to think because they do not do certain things that they see people in a none-religious world do, to look down and judge them thinking they are better than them. Not so, we all have a world to turn from. When a person is born again they have an ordinary life natural to them and are part of the natural world but we all must turn from our world in order to follow Christ

Kept By The Power And Grace Of God

I now had an inward and real desire not to continue in those ways, which I have just mentioned, for they just perpetuated my former sinful self, of which I had, had enough. A change of heart had taken place. This was the fight. That is not to say I could not be tempted to find pleasure in such sins there was a part of me still the same but I had a desire to put to death sinful thoughts and actions. Should I allow wrong affections to move me I was self-condemned with an accompanying self-abhorrence and I knew was not pleasing to God. By the grace of God I was able to resist and fight against sin.